

ITA

MICRO - FICHE AUSGABE 12/86 GUELTIG FUER

VESPA PK 50 XL - VESPA PK 50 XL ELESTART

VESPA PK 125 XL

BEZEICHNUNG	VORZEICHEN	FFG.-NR.	KENNZEICHEN
VESPA PK 50 XL MIT BLINKLEUCHTEN, GEPACKEFACH, ELEKTRONISCHE ZUENDUNG	V5X3T	0000001	401
VESPA PK 50 XL MIT ELEKTROSTARTER, BLINKLEUCHTEN, GEPACKEFACH, ELEKTRONISCHE ZUENDUNG	V5X3T	3000001	406
VESPA PK 125 XL MIT BLINKLEUCHTEN, GEPACKEFACH, ELEKTRONISCHER ZUENDUNG	VMX6T	0003717	431

DER MICRO-FICHE AUSGABE 3/86 IST NICHT MEHR GUELTIG.

ITA

ITAFEL 1	MOTOR	SPALTE 2A	I ABB. BENENNING	I ERSATZTEIL	I ST IKENNZIFFER	I BEMERKUNGEN
			1 MOTOR KPL.	242800	1 1401,	
			1 MOTOR KPL.	244364	A 1 1401,	IA: MIT ABB. DER
			1 MOTOR KPL.	242960	AD 1 1406,	TAF. 2-7, 9-19,
			1 MOTOR KPL.	244365	B 1 1406,	22, 25-28, 30.
			1 MOTOR KPL.	242805	BD 1 1431,	
			2 DICHTUNGSSATZ	154616	C 1 1401, 406,	IB: MIT ABB. DER
			2 DICHTUNGSSATZ	154630	D 1 1431,	TAF. 2-7, 9-18,
			3 MOTORABDECKUNG	227857	D 1 1401, 406,	21, 23, 25-28, 30I
			4 SCHRAUBE	S 015523	D 1 1401, 406,	IC: MIT ABB. 8 TF. 3I
			5 U-SCHEIBE	078307	D 1 1401, 406,	3 TF. 6, 4 TF. 8I
			6 GERAUSCHDAEMM-	227914	D 1 1401, 406,	1-13 TF. 9,
			MATTE FUER MOTOR-			5 TF. 13,
			ABDECKUNG			5 TF. 14,
						1 - 5 TF. 15,
						9 TF. 16,
						14 TF. 27-29,
						13 TF. 28,
						3 TF. 30.
						ID: AB FG.-NR.
						V5X3T0048534

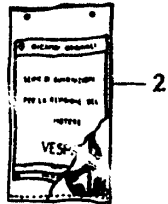
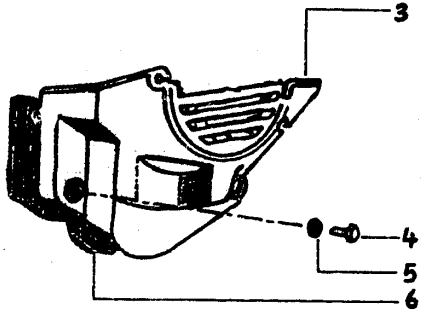
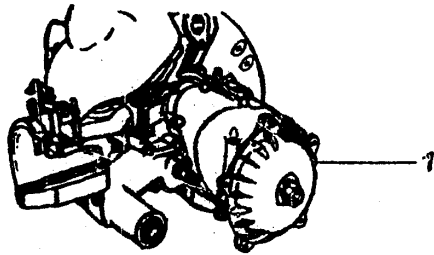

ITAFEL 2	KURBELGEHAUSE	SPALTE 2B	IABB. BENENNUNG	I ERSATZTEIL	I ST	IKENNZIFFER	IBEMERKUNGEN
			1 KURBELGEHAUSE	I 253181	I	1 1401,	IA:MIT ABB. 3-16
			1 KURBELGEHAUSE	I 243183	A I	1 1406,	
			1 KURBELGEHAUSE	I 243178	B I	1 1431,	IB:MIT ABB. 2-16
			2 STEHBOLZEN	I S 016036	C I	2 1406,	IC:MIT ABB. 3-15
			3 NADELHUELSE	I 137731	I	1 1401,406,431,	
			4 MUTTER	I S 020107	I	1 1401,406,431,	
			5 SCHEIBE	I S 003057	I	1 1401,406,431,	
			6 PUFFER	I 165206	I	1 1401,406,431,	
			6 PUFFER	I 240753	I	1 1401,406,431,	
			7 STIFTSCHRAUBE	I S 004515	I	2 1401,406,431,	
			8 STEHBOLZEN	I S 000480	I	4 1401,406,	
			8 STEHBOLZEN	I 150656	I	4 1431,	
			9 STEHBOLZEN	I S 000584	I	3 1401,406,431,	
			10 RING	I 112093	I	2 1401,406,	
			11 GUMMILAGER	I 112040	I	2 1401,406,	
			11 GUMMILAGER M.ROHRI	I 112204	I	2 1431,	
			12 TRAVERSENROHR	I 078587	I	1 1401,406,	
			13 SCHEIBE	I 180470	I	1 1401,406,431,	
			14 GUMMIUNTERLAGE	I 157103	I	1 1401,406,431,	
			15 DISTANZSTUECK	I 223604	I	1 1401,406,431,	
			16 STEHBOLZEN	I S 000456	I	3 1401,406,431,	
			17 PUFFER	I 240753	I	1 1431,	

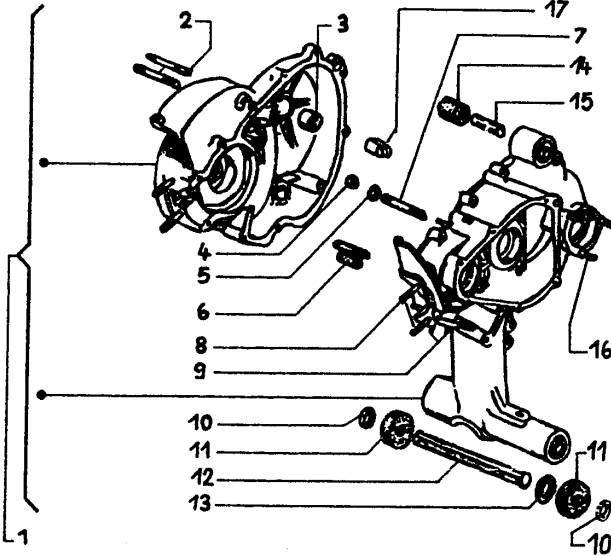

ITAFEL 3	KURBELGEHAUSEBEFESTIGUNG	SPALTE 2C	IABB. BENENNUNG	I ERSATZTEIL	I ST	IKENNZIFFER	IBEMERKUNGEN

ITAFEL

ITAFEL 3	KURBELGEHAEUSEBEFESTIGUNG	SPALTE 2C	I ABB. BENENNUNG	I ERSATZTEIL	I ST IKENNZIFFER	I BEMERKUNGEN	I ITAFEL
			1 SCHRAUBE	S 008499	2	1401,406,431,	
			2 SCHEIBE	S 003057	6	1401,406,431,	
			3 FEDERSCHEIBE	S 016407	7	1401,406,431,	
			4 MUTTER	S 020107	7	1401,406,431,	
			5 SCHRAUBE	S 008421	2	1401,406,431,	
			6 SCHRAUBE	S 008420	6	1401,406,431,	
			7 SCHRAUBE	S 008419	1	1401,406,431,	
			8 DICHTUNG	222429	1	1401,406,431,	

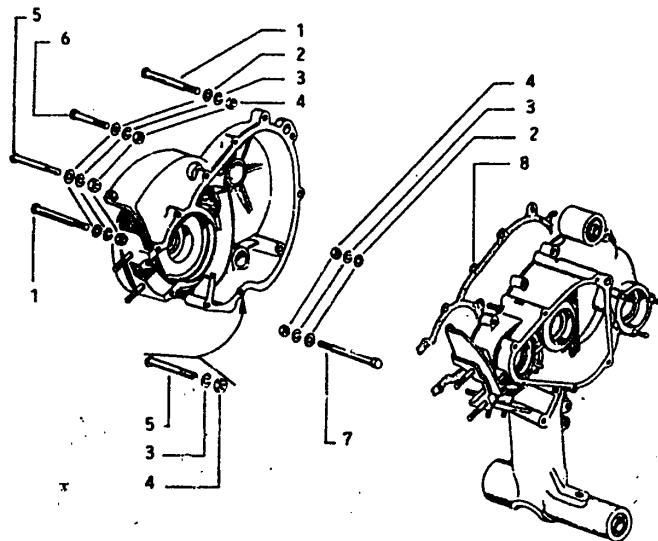

ITAFEL 4	KURBELWELLENLAGER-PRIMAERZAHNRAD	SPALTE 2D	I ABB. BENENNUNG	I ERSATZTEIL	I ST IKENNZIFFER	I BEMERKUNGEN	I ITAFEL
----------	----------------------------------	-----------	------------------	--------------	------------------	---------------	----------

TAFEL 4 KURBELWELLENLAGER-PRIMAERZAHNRAD SPALTE 2D

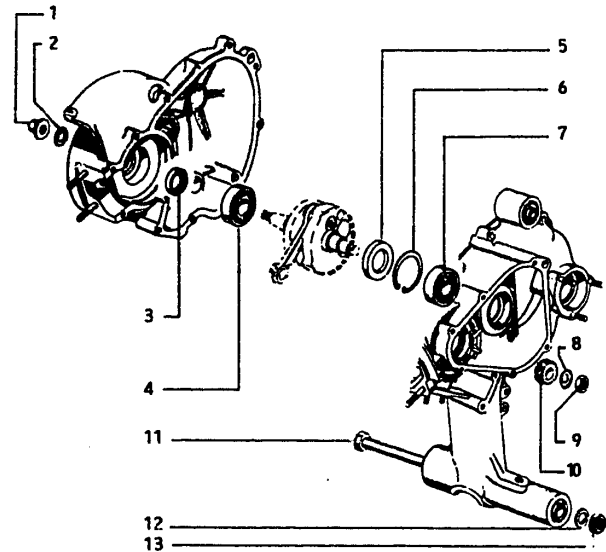

I	I	I	I	I	I	I	I
1	2	3	4	5	6	7	8
9	10	11	12	13	14	15	16
17	18	19	20	21	22	23	24
25	26	27	28	29	30	31	32
33	34	35	36	37	38	39	40
41	42	43	44	45	46	47	48
49	50	51	52	53	54	55	56
57	58	59	60	61	62	63	64
65	66	67	68	69	70	71	72
73	74	75	76	77	78	79	80
81	82	83	84	85	86	87	88
89	90	91	92	93	94	95	96
97	98	99	100	101	102	103	104
105	106	107	108	109	110	111	112
113	114	115	116	117	118	119	120
121	122	123	124	125	126	127	128
129	130	131	132	133	134	135	136
137	138	139	140	141	142	143	144
145	146	147	148	149	150	151	152
153	154	155	156	157	158	159	160
161	162	163	164	165	166	167	168
169	170	171	172	173	174	175	176
177	178	179	180	181	182	183	184
185	186	187	188	189	190	191	192
193	194	195	196	197	198	199	200
201	202	203	204	205	206	207	208
209	210	211	212	213	214	215	216
217	218	219	220	221	222	223	224
225	226	227	228	229	230	231	232
233	234	235	236	237	238	239	240
241	242	243	244	245	246	247	248
249	250	251	252	253	254	255	256
257	258	259	260	261	262	263	264
265	266	267	268	269	270	271	272
273	274	275	276	277	278	279	280
281	282	283	284	285	286	287	288
289	290	291	292	293	294	295	296
297	298	299	300	301	302	303	304
305	306	307	308	309	310	311	312
313	314	315	316	317	318	319	320
321	322	323	324	325	326	327	328
329	330	331	332	333	334	335	336
337	338	339	340	341	342	343	344
345	346	347	348	349	350	351	352
353	354	355	356	357	358	359	360
361	362	363	364	365	366	367	368
369	370	371	372	373	374	375	376
377	378	379	380	381	382	383	384
385	386	387	388	389	390	391	392
393	394	395	396	397	398	399	400
401	402	403	404	405	406	407	408
409	410	411	412	413	414	415	416
417	418	419	420	421	422	423	424
425	426	427	428	429	430	431	432
433	434	435	436	437	438	439	440
441	442	443	444	445	446	447	448
449	450	451	452	453	454	455	456
457	458	459	460	461	462	463	464
465	466	467	468	469	470	471	472
473	474	475	476	477	478	479	480
481	482	483	484	485	486	487	488
489	490	491	492	493	494	495	496
497	498	499	500	501	502	503	504
505	506	507	508	509	510	511	512
513	514	515	516	517	518	519	520
521	522	523	524	525	526	527	528
529	530	531	532	533	534	535	536
537	538	539	540	541	542	543	544
545	546	547	548	549	550	551	552
553	554	555	556	557	558	559	560
561	562	563	564	565	566	567	568
569	570	571	572	573	574	575	576
577	578	579	580	581	582	583	584
585	586	587	588	589	590	591	592
593	594	595	596	597	598	599	600
601	602	603	604	605	606	607	608
609	610	611	612	613	614	615	616
617	618	619	620	621	622	623	624
625	626	627	628	629	630	631	632
633	634	635	636	637	638	639	640
641	642	643	644	645	646	647	648
649	650	651	652	653	654	655	656
657	658	659	660	661	662	663	664
665	666	667	668	669	670	671	672
673	674	675	676	677	678	679	680
681	682	683	684	685	686	687	688
689	690	691	692	693	694	695	696
697	698	699	700	701	702	703	704
705	706	707	708	709	710	711	712
713	714	715	716	717	718	719	720
721	722	723	724	725	726	727	728
729	730	731	732	733	734	735	736
737	738	739	740	741	742	743	744
745	746	747	748	749	750	751	752
753	754	755	756	757	758	759	760
761	762	763	764	765	766	767	768
769	770	771	772	773	774	775	776
777	778	779	780	781	782	783	784
785	786	787	788	789	790	791	792
793	794	795	796	797	798	799	800
801	802	803	804	805	806	807	808
809	810	811	812	813	814	815	816
817	818	819	820	821	822	823	824
825	826	827	828	829	830	831	832
833	834	835	836	837	838	839	840
841	842	843	844	845	846	847	848
849	850	851	852	853	854	855	856
857	858	859	860	861	862	863	864
865	866	867	868	869	870	871	872
873	874	875	876	877	878	879	880
881	882	883	884	885	886	887	888
889	890	891	892	893	894	895	896
897	898	899	900	901	902	903	904
905	906	907	908	909	910	911	912
913	914	915	916	917	918	919	920
921	922	923	924	925	926	927	928
929	930	931	932	933	934	935	936
937	938	939	940	941	942	943	944
945	946	947	948	949	950	951	952
953	954	955	956	957	958	959	960
961	962	963	964	965	966	967	968
969	970	971	972	973	974	975	976
977	978	979	980	981	982	983	984
985	986	987	988	989	990	991	992
993	994	995	996	997	998	999	1000

TAFEL 5 KURBELWELLE - PLEUELLAGER SPALTE 2E

I	I	I	I	I	I	I	I
1	2	3	4	5	6	7	8
9	10	11	12	13	14	15	16
17	18	19	20	21	22	23	24
25	26	27	28	29	30	31	32
33	34	35	36	37	38	39	40
41	42	43	44	45	46	47	48
49	50	51	52	53	54	55	56
57	58	59	60	61	62	63	64
65	66	67	68	69	70	71	72
73	74	75	76	77	78	79	80
81	82	83	84	85	86	87	88
89	90	91	92	93	94	95	96
97	98	99	100	101	102	103	104
105	106	107	108	109	110	111	112
113	114	115	116	117	118	119	120
121	122	123	124	125	126	127	128
129	130	131	132	133	134	135	136
137	138	139	140	141	142	143	144
145	146	147	148	149	150	151	152
153	154	155	156	157	158	159	160
161	162	163	164	165	166	167	168
169	170	171	172	173	174	175	176
177	178	179	180	181	182	183	184
185	186	187	188	189	190	191	192
193	194	195	196	197	198	199	200
201	202	203	204	205	206	207	208
209	210	211	212	213	214	215	216

TAFEL 5	KURBELWELLE - PLEUELLAGER	SPALTE 2E	I ABB. BENENNUNG	I ERSATZTEIL	I ST IKENNZIFFER	I BEMERKUNGEN	I TAFEL
			1 KURBELWELLE	224587	1 1401,406,		
			1 KURBELWELLE	224788	1 1431,	IA: MIT ABB. 4	
			4 NADELKAEFIG	112145	1 1401,406,		
			4 NADELKAEFIG	093233	1 1431,	IB: IN DEN KATEG. 1,2,3,4 LIEFERBAR.	
			5 KEIL	000267	1 1401,406,		
			5 KEIL	000267	2 1431,		

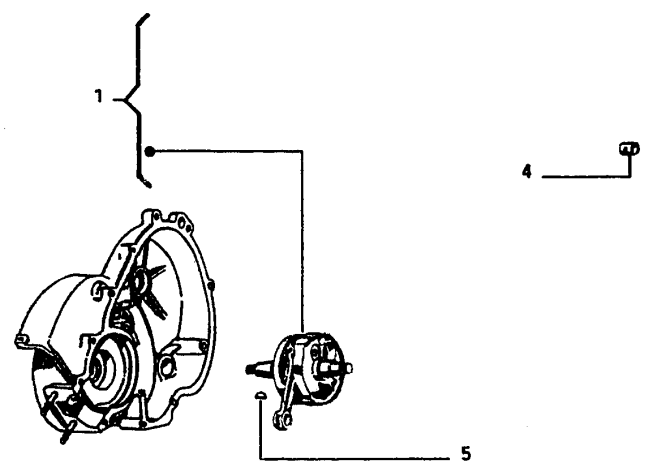

UNGEN	I	I	TAFEL 6	ZYLINDER-KOLBEN-KOLBENBOLZEN	SPALTE 3B	I	ABB. BENENNUNG	I	ERSATZTEIL	I	ST	IKENNZIFFER	I	IBEMERKUNGEN	I
ABB. 3-16	I	I				I	7 KOLBENRING OBEN 2. UEBERMASS	I	196775	I	1	1431,	I		I
ABB. 2-16	I	I				I	7 KOLBENRING 3.UEB.	I	235608	I	2	1401,406,	I		I
ABB. 3-15	I	I				I	7 KOLBENRING UNTEN 3. UEBERMASS	I	158920	I	1	1431,	I		I
	I	I				I	7 KOLBENRING OBEN 3. UEBERMASS	I	196776	I	1	1431,	I		I
	I	I				I	8 STIFTSCHRAUBE	I	S 003918	I	2	1401,406,	I		I
	I	I				I	8 STIFTSCHRAUBE	I	S 003971	I	2	1431,	I		I
	I	I				I	9 ZYLINDER-KOLBEN- KOLBENBOLZEN	I	242929	I	1	1401,406,	I	IC:MIT ABB.6,8.	I
	I	I				I	9 ZYLINDER-KOLBEN- KOLBENBOLZEN	I	243473	I	1	1431,	I		I

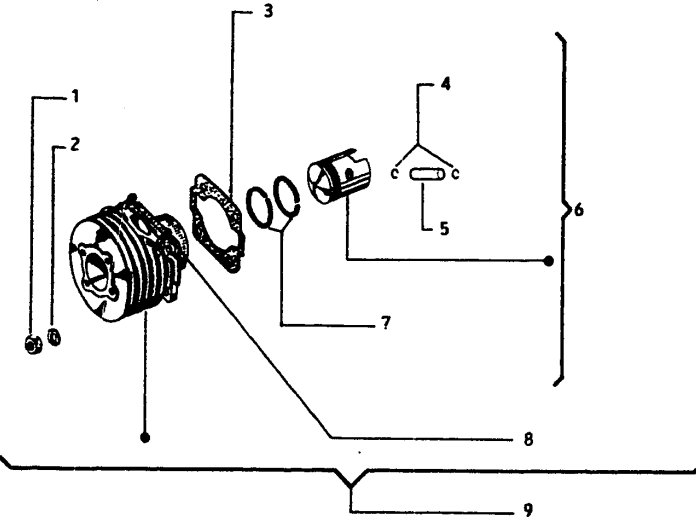

UNGEN	I	I	TAFEL 7	ZYLINDERKOPF-KUEHLHAUBE-ZUENDKERZ	SPALTE 3C	I	ABB. BENENNUNG	I	ERSATZTEIL	I	ST	IKENNZIFFER	I	IBEMERKUNGEN	I
-------	---	---	---------	-----------------------------------	-----------	---	----------------	---	------------	---	----	-------------	---	--------------	---

NGEN	ITAFEL 8	AUSPUFFTOPF	SPALTE 3D	IABB. BENENNUNG	I ERSATZTEIL	I ST IKENNZIFFER	IBEMERKUNGEN
				1 MUTTER	S 020106	2 1401,406,	
				1 MUTTER	S 020108	2 1431,	
				2 ZAHNSCHEIBE	S 012533	2 1401,406,	
				2 ZAHNSCHEIBE	S 012540	2 1431,	
				3 AUSPUFFKRUEMMER	157042	1 1401,406,	
				3 AUSPUFFKRUEMMER	240452	1 1431,	
				4 DICHTUNG	122349	1 1401,406,	
				4 DICHTUNG	230862	1 1431,	
				5 SCHRAUBE	S 030081	1 1401,406,431,	
				6 FEDERRING	S 016408	1 1401,406,431,	
				7 SCHEIBE	S 003058	1 1401,406,431,	
				8 SCHEIBE	078307	2 1401,406,431,	
				9 MUTTER	S 020106	2 1401,406,431,	
				10 AUSPUFF	243190	1 1401,406,	
				10 AUSPUFF	244348	1 1401,406,	IA:AB FG.-NR.
				10 AUSPUFF	234682	1 1431,	V5X3T0048534
				11 DICHTUNG	122349	1 1401,406,	
				12 DICHTUNG	222209	1 1431,	

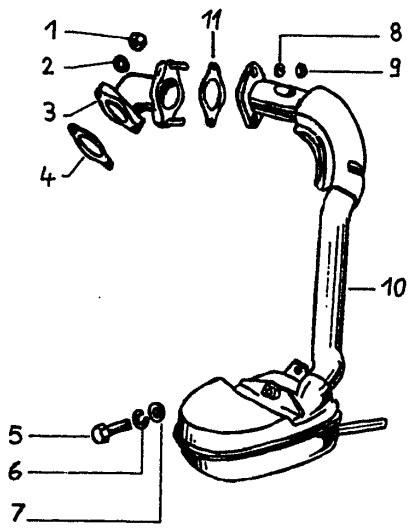

NGEN	ITAFEL 9	KUPLUNGSDECKEL	SPALTE 3E	IABB. BENENNUNG	I ERSATZTEIL	I ST IKENNZIFFER	IBEMERKUNGEN

I TAFEL 10 KUPPLUNG - PK 50 XL

I SPALTE 3F

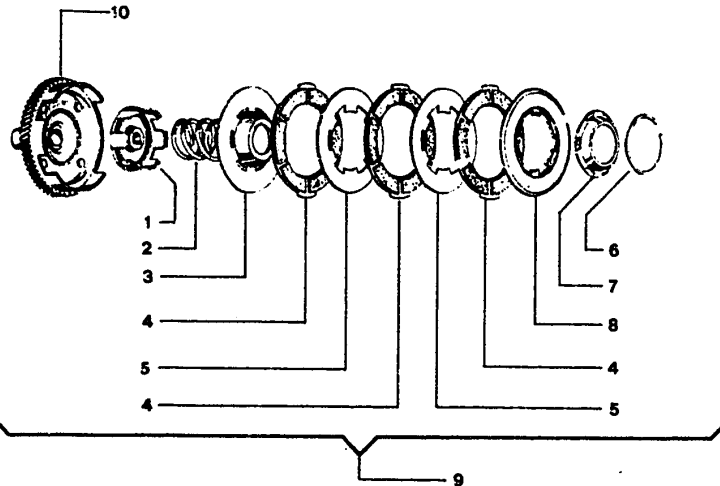

I ABB. BENENNUNG	I ERSATZTEIL	I ST	I KENNZIFFER	I BEMERKUNGEN
I 1 KUPPLUNGSGEHAUSE	I 309652	I 1	I 1401,406,	I
I 2 FEDER	I 112390	I 1	I 1401,406,	I
I 3 FEDERTELLER	I 079469	I 1	I 1401,406,	I
I 4 KORBLAMELLE	I 079399	I 3	I 1401,406,	I
I 5 STAHLAMELLE	I 079478	I 2	I 1401,406,	I
I 6 SPRENGRING	I 079474	I 1	I 1401,406,	I
I 7 OELABLASSTELLER	I 150508	I 1	I 1401,406,	I
I 8 AUESSERE LAMELLE	I 079476	I 1	I 1401,406,	I
I 9 KUPPLUNG KPL.	I 150514	I 1	I 1401,406,	I
I 10 KUPPLUNGSKORB	I 165006	I 1	I 1401,406,	I

IA:MIT ABB. 1 - 8I

I TAFEL 10/1 KUPPLUNGSKORB - PK 125 XL SPALTE 36

ABB. BENENNUNG	ERSATZTEIL	ST	IKENNZIFFER	IBEMERKUNGEN
1 KUPPLUNGSKORB KPLI	110670	1	1431,	IA:MIT ABB. 2 - 8I
2 SCHEIBE	078495	1	1431,	
3 FEDER	078484	4	1431,	
4 ZAHNRAD	110921	1	1431,	
5 DRUCKKOLBEN	078594	4	1431,	
6 KUPPLUNGSKORB	110669	1	1431,	
7 KUPPLUNGSFEDER- TELLER	110668	1	1431,	
8 NIET	S 005772	4	1431,	

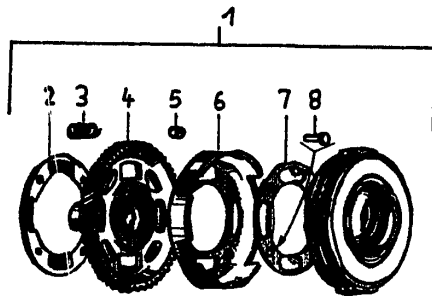

I TAFEL 10/2 KUPPLUNG - PK 125 XL

I SPALTE 3H



ABB. BENENNUNG	ERSATZTEIL	ST	IKENNZIFFER	IBEMERKUNGEN
1 INNERES KUPPLUNGSGEHAUESE	309652	1	1431,	
2 FEDER	126280	1	1431,	
3 FEDER	126281	1	1431,	
4 FEDERTELLER	126282	1	1431,	
5 INNERE SCHEIBE	079469	1	1431,	
6 KORKLAMELLE	079399	3	1431,	
7 STAHLAMELLE	079478	2	1431,	
8 SPRENGRING	079474	1	1431,	
9 OELABLASSTELLER	150508	1	1431,	
10 AEUSSERE LAMELLE	079476	1	1431,	
11 KUPPLUNG KPL.	127427	1	1431,	IA:MIT ABB. 1-10

GEN	I	I	I	I	I	I	I	I	I	I	I
		TAFEL 12	SCHALTGETRIEBE	SPALTE 4B	I	ERSATZTEIL	I	ST	IKENNZIFFER	IBEMERKUNGEN	I
					I	134902	I	1	1401,406,431,	I	I
					I	138393	I	1	1401,406,431,	I	I
					I	165418	I	1	1401,406,431,	I	I
					I	165417	I	1	1401,406,431,	I	I
					I	165416	I	1	1401,406,431,	I	I
					I	165415	I	1	1401,406,431,	I	I
					I	S 005901	I	1	1401,406,431,	I	I
					I	134903	I	1	1401,406,431,	I	I
					I	134904	I	1	1401,406,431,	I	I
					I	182541	I	1	1401,406,431,	I	I
					I	S 006379	I	2	1401,406,431,	I	I
					I	150110	I	1	1401,406,431,	I	I
					I	S 005901	I	1	1401,406,431,	I	I
					I	138393	I	1	1401,406,431,	I	I
					I	165418	I	1	1401,406,431,	I	I
					I	165417	I	1	1401,406,431,	I	I
					I	165416	I	1	1401,406,431,	I	I
					I	165415	I	1	1401,406,431,	I	I
					I	134906	I	1	1401,406,431,	I	I
					I	134905	I	1	1401,406,431,	I	I

3.6,8.

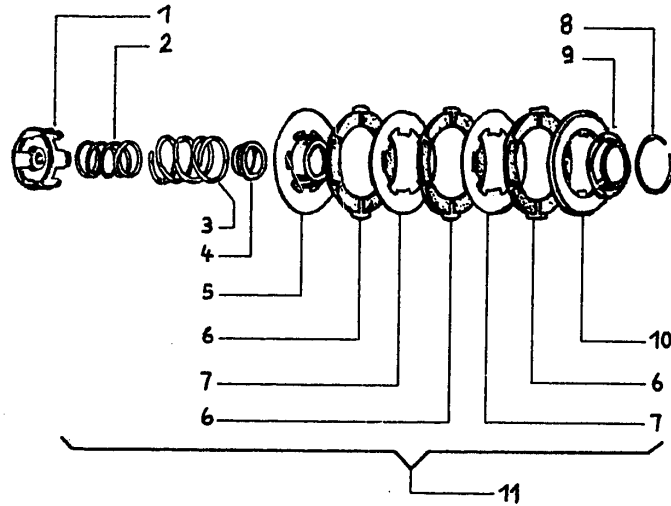
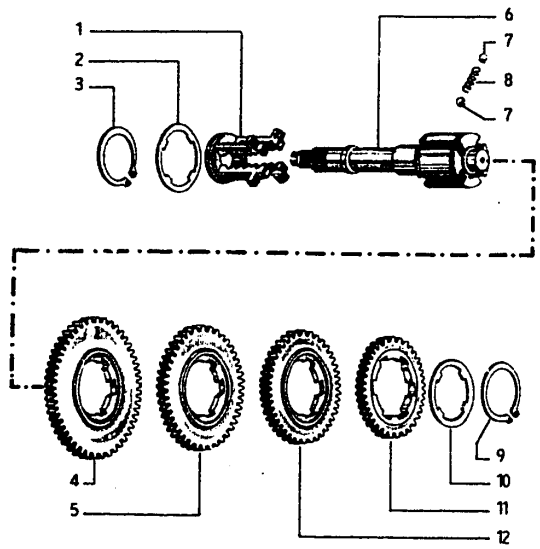

EN	I	I	I	I	I	I	I	I	I	I	I
		TAFEL 13	SCHALTGABEL - SCHALTRASTE	SPALTE 4C	I	ERSATZTEIL	I	ST	IKENNZIFFER	IBEMERKUNGEN	I

NR. 48534



ABB. BENENNUNG	ERSATZTEIL	ST	IKENNZIFFER	IBEMERKUNGEN
1 SCHRAUBE	098787	1	I401,406,431,	
2 NIETE	S 005771	2	I401,406,431,	
3 HALTER	078526	1	I401,406,431,	
4 FEDERRING	078597	1	I401,406,431,	
5 O-RING	S 006706	1	I401,406,431,	
6 DISTANZSCHEIBE	098788	1	I401,406,431,	
7 SCHALTGABEL	078944	1	I401,406,431,	
8 DRUCKSTUECK	078945	2	I401,406,431,	
9 FEDERRING	S 005962	2	I401,406,431,	
10 SCHALTGABEL KPL.	179383	1	I401,406,431,	IA: MIT ABB. 2, 3, 5,
11 SCHALTRASTHEBEL	179487	1	I401,406,431,	7, 8, 9, 11, 12.
12 KEGELSTIFT	S 013010	1	I401,406,431,	
13 DECKEL	178477	1	I401,406,431,	
14 FEDERRING	S 006975	1	I401,406,431,	
15 SCHRAUBE	S 015598	1	I401,406,431,	

EN	ITAFEL 14	KICKSTARTER	SPALTE 4D	ABB. BENENNUNG	ERSATZTEIL	ST	IKENNZIFFER	IBEMERKUNGEN	ITAF
----	-----------	-------------	-----------	----------------	------------	----	-------------	--------------	------

EN	ITAFEL 14	KICKSTARTER	SPALTE 4D	I	ABB. BENENNUNG	I	ERSATZTEIL	I	ST	IKENNZIFFER	IBEMERKUNGEN	I	ITAFEL
					1	DRUCKFEDER	151493		1	1401,406,431,			
					2	ZAHNRAD	078473		1	1401,406,431,			
					3	RUECKHOLFEDER	078478		1	1401,406,431,			
					4	STARTERSEGMENT	078976		1	1401,406,431,			
					5	DICHTUNG	S 006721		1	1401,406,431,			
					6	DISTANZSCHEIBE	151743		1	1401,406,431,			
					7	SPRENGRING	S 006425		1	1401,406,431,			
					8	KUGELLAGER	S 007130		1	1401,406,431,			
					9	SPRENGRING	S 006647		1	1401,406,431,			
					10	KICKSTARTERBOLZEN	S 000906		1	1401,406,431,			
					11	ZAHNSCHEIBE	S 012563		1	1401,406,431,			
					12	KICKSTARTERHEBEL	234351		1	1401,406,431,			

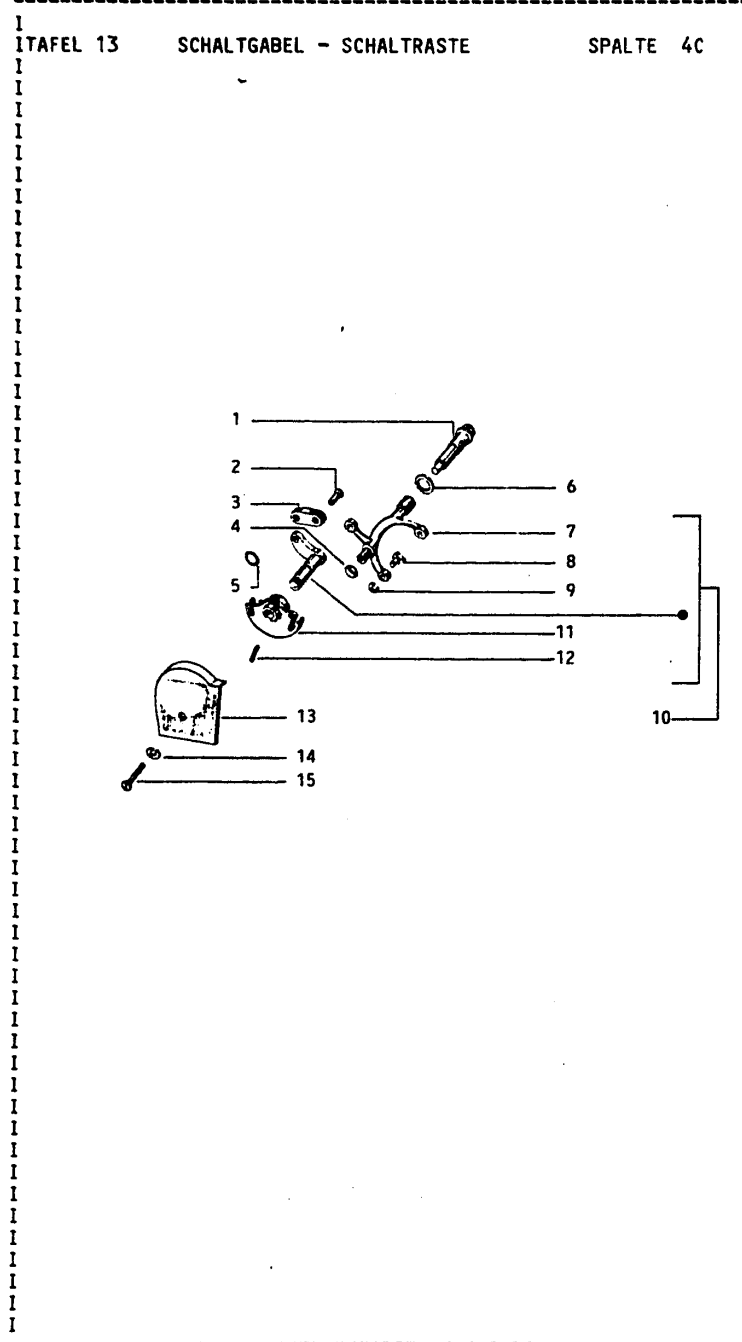
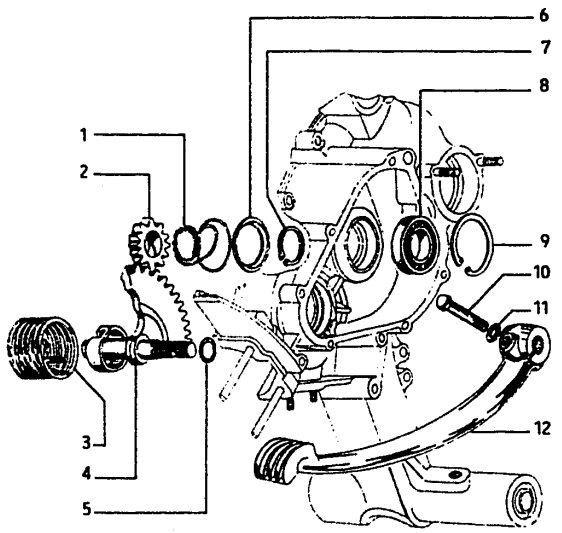

IR. 8534

N	ITAFEL 15	LAGER FUER ANTRIEBSWELLE	SPALTE 4E	I	ABB. BENENNUNG	I	ERSATZTEIL	I	ST	IKENNZIFFER	IBEMERKUNGEN	I	ITAFEL
---	-----------	--------------------------	-----------	---	----------------	---	------------	---	----	-------------	--------------	---	--------

N	TAFEL 15	LAGER FUER ANTRIEBSWELLE	SPALTE 4E	I ABB. BENENNUNG	I ERSATZTEIL	I ST IKENNZIFFER	I BEMERKUNGEN	I TAFEL
				1 DICHTUNG	090899	1 1401,406,431,		
				2 DICHTRING	046699	1 1401,406,431,		
				3 KUGELLAGER	090025	1 1401,406,431,		
				4 SCHRAUBE	138345	2 1401,406,431,		
				5 DICHTUNG	000397	2 1401,406,431,		
				6 MUTTER	S 020105	2 1401,406,431,		
				7 STELSCHRAUBE	090527	2 1401,406,431,		
				8 ENTLUEFTER	019301	1 1401,406,431,		

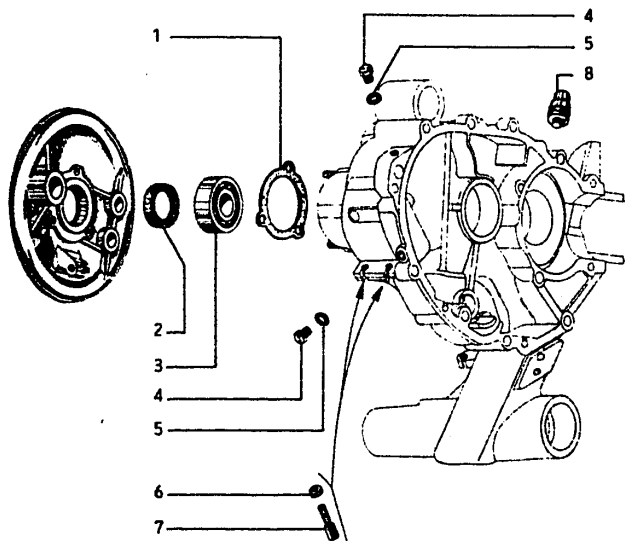

11-13

N	TAFEL 16	HINTERRADBREMSE	SPALTE 4F	I ABB. BENENNUNG	I ERSATZTEIL	I ST IKENNZIFFER	I BEMERKUNGEN	I TAFEL
---	----------	-----------------	-----------	------------------	--------------	------------------	---------------	---------

1
2 - 8

TAFEL 17 HINTERRADBREMSTROMMEL

SPALTE 4G



ABB. BENENNUNG	ERSATZTEIL	ST	KENNZIFFER	BEMERKUNGEN
1 U-SCHEIBE	183980	1	1401,406,431,	
2 MUTTER	194424	1	1401,406,431,	
3 SICHERUNGSKAPPE	194423	1	1401,406,431,	
4 ABDECKKAPPE	215917	1	1401,406,431,	
5 SPLINT	S 012789	1	1401,406,431,	
6 MUTTER	S 020108	5	1401,406,431,	
7 FEDERRING	S 016408	5	1401,406,431,	
8 SCHRAUBBOLZEN	085914	5	1401,406,431,	
9 BREMSTROMMEL	215993	1	1401,406,431,	

A
A: MIT ABB. 8

ERKUNGEN

ITAFEL 18

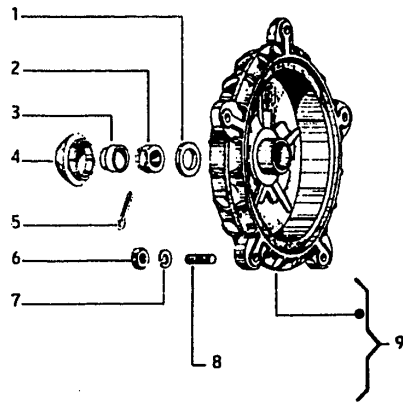
LUEFTERGEHAEUSEDECKEL

SPALTE 5A

I ABB. BENENNUNG I ERSATZTEIL I ST IKENNZIFFER IBEMERKUNGEN I

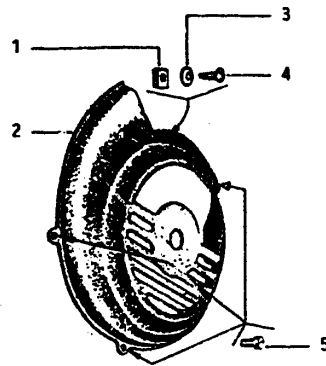

I ABB. BENENNUNG	I ERSATZTEIL	I ST	IKENNZIFFER	IBEMERKUNGEN
I 1 FEDERPLATTE	I S 008112	I 1	I 1401,406,431,	I
I 2 LUEFTERGEHAEUSE- I DECKEL	I 179138	I 1	I 1401,406,431,	I
I 3 SCHEIBE	I 078307	I 1	I 1401,406,431,	I
I 4 BLECHSCHRAUBE	I S 008265	I 1	I 1401,406,431,	I
I 5 SCHRAUBE	I S 018509	I 3	I 1401,406,431,	I

||||| A 5 |||||

ERKUNGEN

ITAFEL 19

LICHTMASCHINE (OHNE ELEKTROSTART)

SPALTE 5B

I ABB. BENENNUNG I ERSATZTEIL I ST IKENNZIFFER IBEMERKUNGEN I

ITA

IRKUNGEN

ITAFEL 19 LICHTMASCHINE (OHNE ELEKTROSTART) SPALTE 5B

I ABB. BENENNUNG I ERSATZTEIL I ST IKENNZIFFER IBEMERKUNGEN



ABB. BENENNUNG	ERSATZTEIL	ST	IKENNZIFFER	IBEMERKUNGEN
1 ANKERPLATTE KPL.	199495	1	I401,	IA:MIT ABB. 3 - 8I
2 HALTEBAND	307166	1	I401,	
3 LICHTSPULE	193878	1	I401,	
4 SPULE	231095	1	I401,	
5 SPULE	166657	1	I401,	
6 PICK-UP	196549	1	I401,	
7 PLECHSCHRAUBE	S 015737	1	I401,	
8 SPULE	231095	1	I401,	
9 SCHELLE	216142	1	I401,	
10 SCHEIBE	S 016405	1	I401,	
11 SCHRAUBE	S 015585	1	I401,	
12 U-SCHEIBE	090045	3	I401,	
13 FEDERRING	S 006965	3	I401,	
14 SCHRAUBE	S 015585	3	I401,	
15 ROTOR	224671	1	I401,	
16 LICHTMASCHINE KPL.	224672	1	I401,	IB:MIT ABB. 1-15

IRKUNGEN

ITAFEL 19/1 LICHTMASCHINE - PK 125 XL SPALTE 5C

I ABB. BENENNUNG I ERSATZTEIL I ST IKENNZIFFER IBEMERKUNGEN

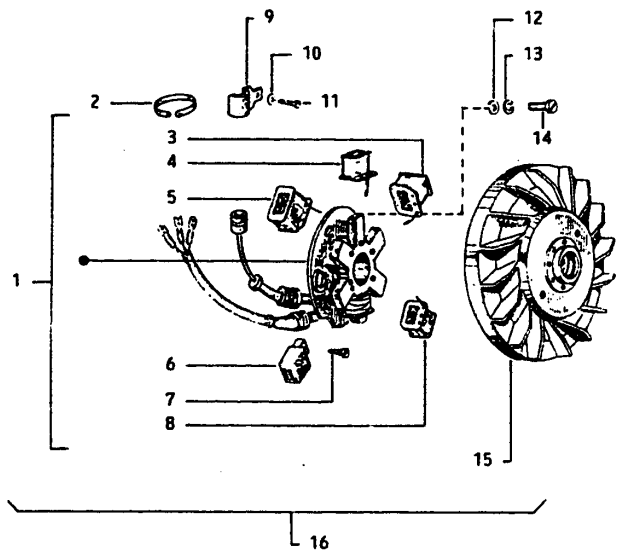
ITA

ITAE

KUNGEN

ITAFEL 19/1 LICHTMASCHINE - PK 125 XL SPALTE 5C

I ABB. BENENNUNG I ERSATZTEIL I ST IKENNZIFFER IBEMERKUNGEN I

ABB. 2, 3, 5, 9, 11, 12.

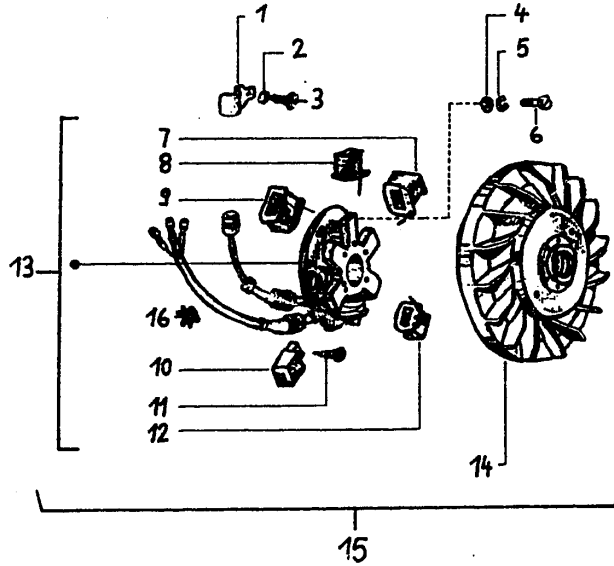

I ABB. BENENNUNG	I ERSATZTEIL	I ST	IKENNZIFFER	IBEMERKUNGEN
1 SCHELLE	216142	1	1431,	
2 SCHEIBE	S 016405	1	1431,	
3 SCHRAUBE	S 015585	1	1431,	
4 SCHEIBE	090045	3	1431,	
5 FEDERRING	S 006965	3	1431,	
6 SCHRAUBE	S 015585	3	1431,	
7 LICHTSPULE	193878	1	1431,	
8 SPULE	231095	1	1431,	
9 SPULE	166657	1	1431,	
10 PICK-UP	196549	1	1431,	
11 SCHRAUBE	S 015737	1	1431,	
12 SPULE	231095	1	1431,	
13 ANKERPLATTE KPL.	199495	1	1431,	IA: MIT ABB. 7-12
14 ROTOR	223602	1	1431,	
15 LICHTMASCHINE KPL	223603	1	1431,	IB: MIT ABB. 13-14

KUNGEN

ITAFEL 20 LICHTMASCHINE (MIT ELEKTROSTART) SPALTE 5D

I ABB. BENENNUNG I ERSATZTEIL I ST IKENNZIFFER IBEMERKUNGEN I

KUNGEN	TAFEL 20	LICHTMASCHINE (MIT ELEKTROSTART)	SPALTE 5D	I ABB. BENENNUNG	I ERSATZTEIL	I ST IKENNZIFFER	I BEMERKUNGEN
				1 ANKERPLATTE KPL.	199495	1 1406,	IA: MIT ABB. 3 - 8I
				2 HALTEBAND	307166	1 1406,	
				3 LICHTSPULE	193878	1 1406,	
				4 SPULE	231095	1 1406,	
				5 SPULE	166657	1 1406,	
				6 PICK-UP	196549	1 1406,	
				7 BLECHSCHRAUBE	S 015737	1 1406,	
				8 SPULE	231095	1 1406,	
				9 SCHELLE	216142	1 1406,	
				10 SCHEIBE	S 016405	1 1406,	
				11 SCHRAUBE	S 015585	1 1406,	
				12 U-SCHEIBE	090045	3 1406,	
				13 FEDERRING	S 006965	3 1406,	
				14 SCHRAUBE	S 015585	3 1406,	
				15 ROTOR	199454	1 1406,	
				16 LICHTMASCHINE	234322	1 1406,	IB: MIT ABB. 1-15

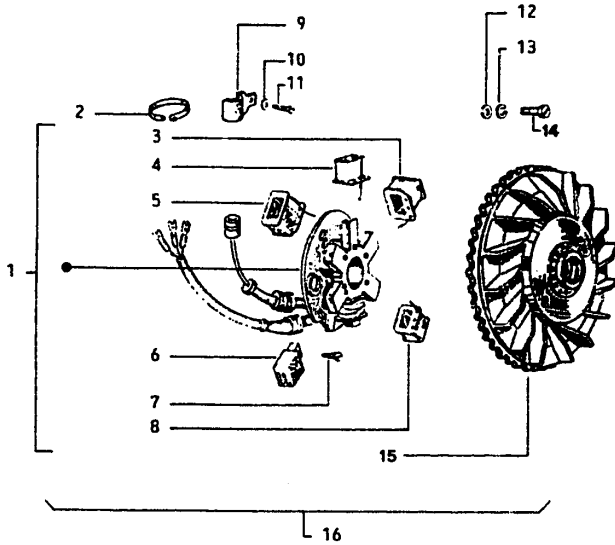

KUNGEN	TAFEL 21	ELEKTRONISCHE ZUENDVORRICHTUNG	SPALTE 5E	I ABB. BENENNUNG	I ERSATZTEIL	I ST IKENNZIFFER	I BEMERKUNGEN
--------	----------	--------------------------------	-----------	------------------	--------------	------------------	---------------

UNGEN

I TAFEL 21 ELEKTRONISCHE ZUENDVORRICHTUNG SPALTE 5E

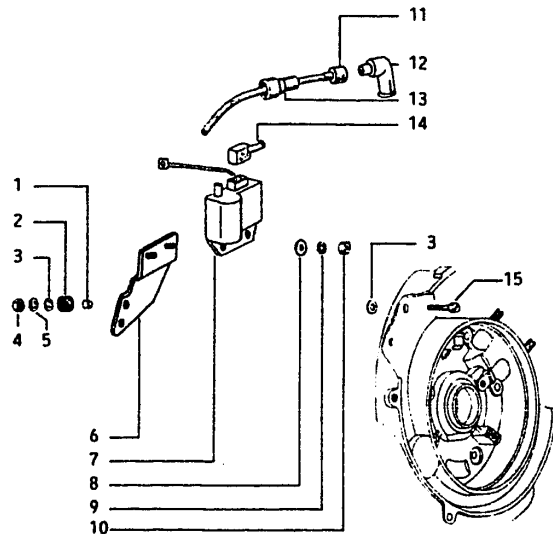

I IABB. BENENNUNG I ERSATZTEIL I ST IKENNZIFFER IBEMERKUNGEN I

IABB. BENENNUNG	ERSATZTEIL	ST	IKENNZIFFER	IBEMERKUNGEN
I 1 BUCHSE	I 141589	I 2	I 1401,406,431,	I
I 2 GUMMI	I 141590	I 2	I 1401,406,431,	I
I 3 FEDERSTUETZRING	I S 006018	I 4	I 1401,406,431,	I
I 4 MUTTER	I S 020005	I 2	I 1401,406,431,	I
I 5 SCHEIBE	I S 016405	I 2	I 1401,406,431,	I
I 6 HALTER	I 179103	I 1	I 1401,406,431,	I
I 7 ELEKTRONISCHE ZUENDZENTRALE	I 199055	I 1	I 1401,406,431,	I
I 8 U-SCHEIBE	I S 006125	I 2	I 1401,406,431,	I
I 9 FEDERRING	I S 016406	I 2	I 1401,406,431,	I
I 10 MUTTER	I S 020106	I 2	I 1401,406,431,	I
I 11 GUMMIKAPPE	I 071671	I 1	I 1401,406,	I
I 12 ENTSTOERSTECKER	I 029465	I 1	I 1401,406,431,	I
I 13 ISOLIERKAPPE	I 231571	I 1	I 1401,406,	I
I 13 ISOLIERKAPPE	I 071671	I 1	I 1431,	I
I 14 KAPPE	I 216918	I 1	I 1401,406,431,	I
I 15 SCHRAUBE	I S 015901	I 2	I 1401,406,431,	I

INGEN

I TAFEL 22 ANLASSERMOTOR SPALTE 5F

I IABB. BENENNUNG I ERSATZTEIL I ST IKENNZIFFER IBEMERKUNGEN I

TAFEL 24	VERGASER KPL. - GASSCHIEBER	SPALTE 5H	IABB. BENENNUNG	I ERSATZTEIL I	I ST IKENNZIFFER	IBEMERKUNGEN
						IA: MIT ABB. 2-23, I
			1 VERGASER	242820	1 1401,406,	I UND DEN ABB. I
			1 VERGASER	242951	A 1 1431,	I DER TAFEL 25 I
			2 FEDERRING	S 016404	A 1 1401,406,431,	I I
			3 MUTTER	S 012012	1 1401,406,431,	I I
			4 GASVENTILDECKEL	178733	1 1401,406,	I I
			4 GASVENTILDECKEL	178686	1 1431,	I I
			5 DICHTUNG	085286	1 1401,406,431,	I I
			6 FEDER	098132	1 1401,406,	I I
			6 FEDER	152074	1 1431,	I I
			7 SCHRAUBE	S 015946	1 1401,406,431,	I I
			8 DICHTUNG	113312	1 1401,406,431,	I I
			9 SCHRAUBE	085418	2 1401,406,431,	I I
			10 HEBEL	178687	1 1401,406,431,	I I
			11 SCHRAUBE	092403	1 1401,406,431,	I I
			12 SCHRAUBE	098137	1 1401,406,431,	I I
			13 SCHRAUBENFEDER	013991	1 1401,406,431,	I I
			14 DICHTUNG	179205	1 1401,406,	I I
			14 DICHTUNG	196694	1 1431,	I I
			15 FEDER	098130	1 1401,406,431,	I I
			16 STELLSCHRAUBE	098128	1 1401,406,431,	I I
			17 HALTEBUEGEL	098147	1 1401,406,	I I
			17 HALTEBUEGEL	196345	1 1431,	I I
			18 GASSCHIEBER	244588	1 1401,406,	I I
			18 GASSCHIEBER	196342	1 1431,	I I
			19 BEFEST.-SCHELLE	136577	B 1 1401,406,431,	I IB: ANSAUGSTUTZEN- I
			19 BEFEST.-SCHELLE	245449	1 1401,406,	I I SCHUTZ ET.-NR. I
			20 LEERLAUFDUESE	42 141616	1 1401,406,	I IC: ANSAUGSTUTZEN- I
			20 LEERLAUFDUESE	199922	1 1431,	I I SCHUTZ ET.-NR. I
						I 245197 I

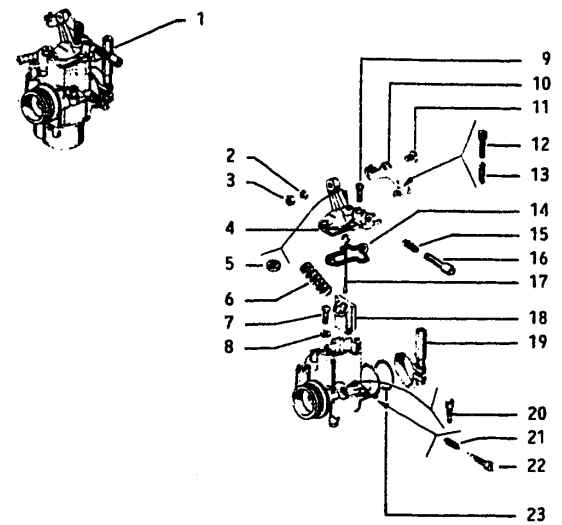

ITAFEL 26	ANSAUGSTUTZEN	SPALTE SK	I ABB. BENENNUNG	I ERSATZTEIL	I ST IKENNZIFFER	I BEMERKUNGEN
			1 FEDERRING	S 016406	3 1401,406,431,	
			2 MUTTER	S 020006	3 1401,406,431,	
			3 DICHTUNG	196931	1 1401,406,431,	
			4 ANSAUGSTUTZEN	198152	1 1401,406,	
			4 ANSAUGSTUTZEN	224755	1 1431,	
			5 DICHTRING	S 008736	1 1401,406,	
			6 ANSAUGSTUTZEN-SCHUTZ	178727	1 1401,406,	
			6 ANSAUGSTUTZEN-SCHUTZ	245197	1 1401,406,	IA:AB NOVEMBER 86I
			7 SPRENGRING	110007	1 1401,406,	MONTIERT
			8 GUMMIMUFFE	178694	1 1401,406,	
			8 GUMMIMUFFE	224781	1 1431,	

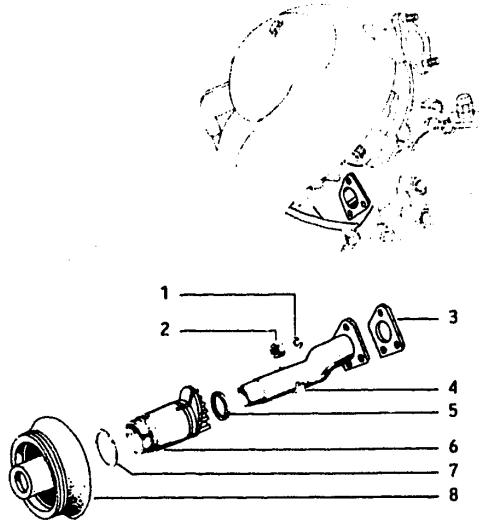

UNGEN
 ABB. 3 - 8
 ABB. 1-15



ABB. BENENNUNG	ERSATZTEIL	ST	IKENNZIFFER	IBEMERKUNGEN
1 TRITTBRETT	I 214512	I 1	I 1401,406,431,	I
2 BLECHSCHRAUBE	I S 018511	I 4	I 1401,406,	I
2 BLECHSCHRAUBE	I S 008455	I 4	I 1431,	I
3 FUSSMATTE RECHTS	I 234171	I 1	I 1401,406,431,	I
3 FUSSMATTE LINKS	I 234172	I 1	I 1401,406,431,	I
4 MUTTER	I 199190	I 1	I 1401,406,431,	I
5 STEUERROHRSCHUTZ	I 226726	I 1	I 1401,406,431,	I
6 SCHRAUBE	I S 015729	I 1	I 1401,406,431,	I
7 PIAGGIO-PLAKETTE	I 198122	I 1	I 1401,406,431,	I
8 FEDERSCHEIBE	I 183774	I 2	I 1401,406,431,	I
9 SCHRAUBE	I S 008457	I 2	I 1401,406,431,	I
10 SCHEIBE	I S 003055	I 2	I 1401,406,431,	I
11 SCHRAUBE	I S 018534	I 2	I 1401,406,431,	I

TAFEL

JNGEN	TAFEL 29	GEPAECKFACH	SPALTE 6C	IABB. BENENNUNG	I ERSATZTEIL	I ST	IKENNZIFFER	IBEMERKUNGEN	I TAFEL
				1 SCHRAUBE	S 008457	2	1401,406,431,		
				2 SCHRAUBE	S 015994	2	1401,406,431,		
				3 SCHRAUBE	S 008451	2	1401,406,431,		
				4 STIFT	231243	2	1401,406,431,		
				5 SCHRAUBE	S 008372	4	1401,406,431,		
				6 HALTER RECHTS	231241	1	1401,406,431,		
				6 HALTER LINKS	231242	1	1401,406,431,		
				7 GUMMIPUFFER	216486	2	1401,406,431,		
				8 GEPAECKFACH- UNTERTEIL	230951	1	1401,406,431,		
				9 KLAPPE	231078	1	1401,406,431,		
				10 PLAKETTE PK 50 XLI	227488	1	1401,		
				10 PLAKETTE PK125XL	227563	1	1431,		
BB. 7-12				11 GEPAECKFACH KPL.	234004	1	1401,406,431,	IC:MIT ABB. 1 - 9	
BB. 13-14				12 SCHRAUBE	226164	2	1401,406,		
				13 PLAKETTE PK 50 XL ELESTARTI	227473	1	1406,		
				14 FEDERMUTTER	S 008108	2	1401,406,431,		

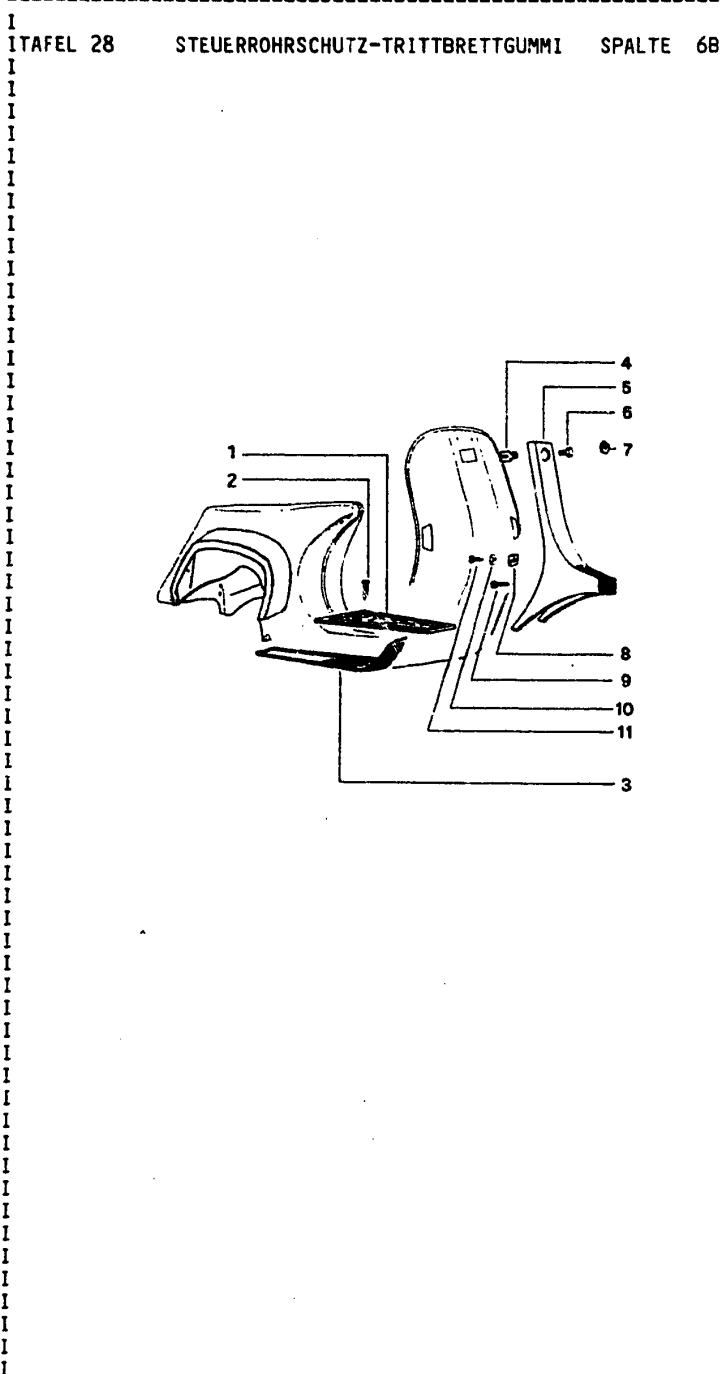
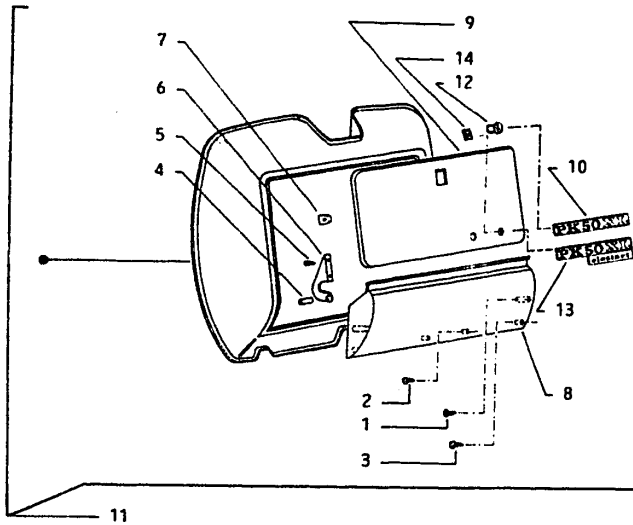

JNGEN	TAFEL 30	GERPAECKFACHSCHLOSS	SPALTE 6D	IABB. BENENNUNG	I ERSATZTEIL	I ST	IKENNZIFFER	IBEMERKUNGEN	I TAFEL
-------	----------	---------------------	-----------	-----------------	--------------	------	-------------	--------------	---------

NGEN
 BB. 3 - 8
 3B. 1-15

TAFEL 30 GERPAECKFACHSCHLOSS SPALTE 6D

ABB. BENENNUNG	ERSATZTEIL	ST	KENNZIFFER	IBEMERKUNGEN
1 FEDER	073260	1	1401,406,431,	
2 SCHLOSS	219415	1	1401,406,431,	
3 FEDER	073111	1	1401,406,431,	
4 HEBEL	178961	1	1401,406,431,	
5 SCHEIBE	177835	1	1401,406,431,	

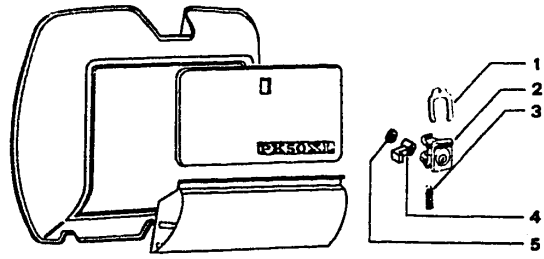

LUNGEN	TAFEL 31	BENZINTANK-ANZEIGER-WERKZEUGBEH. SPALTE 7A	I ABB. BENENNUNG	I ERSATZTEIL	I ST IKENNZIFFER	I BEMERKUNGEN
			1 DECKEL	219002	1 1401,406,431	
			2 BENZINSTAND-ANZEIGER	230885	1 1401,406,431	IA: MIT ABB. 3
			3 DICHTUNG	217618	1 1401,406,431	
			4 SCHRAUBE	S 031117	2 1401,406,431	
			5 FEDERRING	S 016408	2 1401,406,431	
			6 SCHEIBE	S 003058	2 1401,406,431	
			7 HALTER F. KABEL	230965	1 1401,406,431	
			8 HALTEBRUECKE	226890	1 1401,406,431	
			9 BENZINTANK	234498	1 1401,406,431	
			10 TANKDECKEL	242627	1 1401,406,431	
			11 GERAEU SCHDAEMM-PLATTE	198027	1 1401,406,431	
			12 GERAEU SCHDAEMM-MATTE	199603	1 1401,406,431	
			13 WERKZEUGBEHAELTER	219383	1 1401,406,431	

ABDECKUNG
6 IN ROT
ABDECKUNG
6 IN WEISS
ITHRAZIT

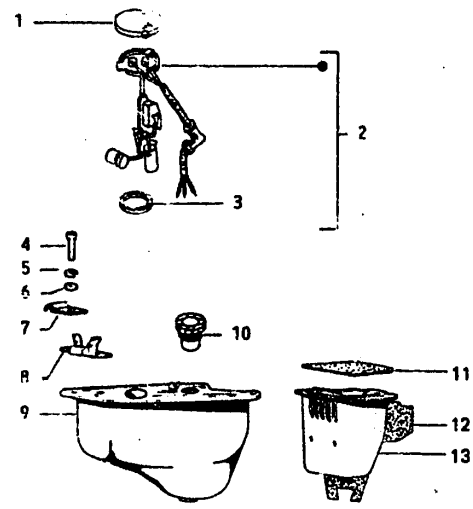

TIG FUER
ERMODELL

LUNGEN	TAFEL 32	BENZINHAHN SPALTE 7B	I ABB. BENENNUNG	I ERSATZTEIL	I ST IKENNZIFFER	I BEMERKUNGEN
--------	----------	----------------------	------------------	--------------	------------------	---------------

NGEN	TAFEL 33	KIPPSTAENDER	SPALTE 7C	ABB. BENENNUNG	ERSATZTEIL	ST	IKENNZIFFER	IBEMERKUNGEN
				1 KIPPSTAENDER	216247	A	1 1401,406,431,	IA:MIT ABB. 2
				2 KIPPSTAENDERFUSS	176166		2 1401,406,431,	
				3 GUMMIPUFFER	216256		2 1401,406,431,	
				4 SCHRAUBE	S 031088		4 1401,406,431,	
				5 HALTER RECHTS	233120		1 1401,406,431,	
				5 HALTER LINKS	233121		1 1401,406,431,	
				6 PLATTE	233122		2 1401,406,431,	
				7 SCHEIBE	S 003056		4 1401,406,431,	
				8 FEDERRING	S 016406		4 1401,406,431,	
				9 MUTTER	S 020006		4 1401,406,431,	
				10 FEDER	216255		2 1401,406,431,	

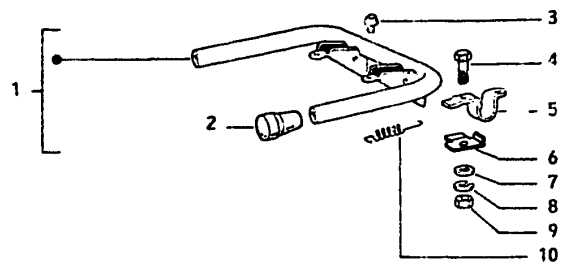

3B. 1 - 91

IGEN

ITAFEL 34 LENK-SITZBANK-HELMHAKENSCHLOSS SPALTE 7D

1	2	3	4	5	6	7	
1	ABB. BENENNUNG	1	ERSATZTEIL	1	ST IKENNZIFFER	1	IBEMERKUNGEN
1	SCHLUESSEL	178907		2	1401,406,431,	IA:BEI BESTELLUNG I	
2	SCHLOSSZYLINDER MIT SCHLUESSEL	196486	A	1	1401,406,431,	SCHLUESSEL-NR. I	
	SCHLOSSZYLINDER-SATZ (FUER SITZBANK, HELMHAKEN UND LENKSCHLOSS)	196467	B	1	1401,406,431,	IB:MIT ABB. 1	

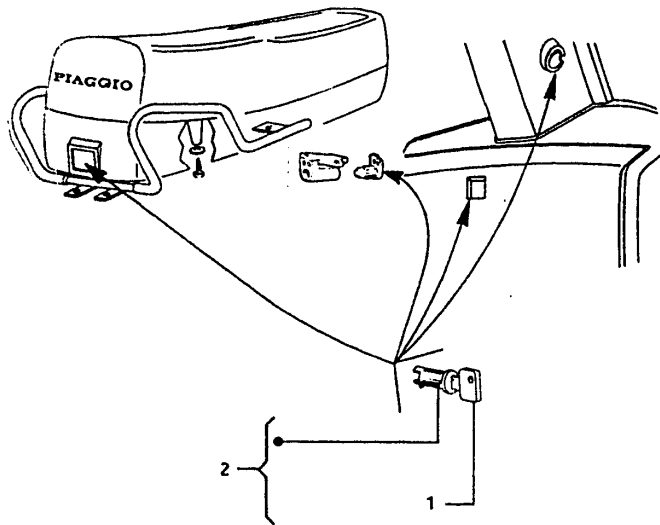

ITAFEL 35 SITZBANK SPALTE 7E I ABB. BENENNUNG I ERSATZTEIL I ST IKENNZIFFER I IBEMERKUNGEN

ITAFEL 35	SITZBANK	SPALTE 7E	I	ABB. BENENNUNG	I	ERSATZTEIL	I	ST	IKENNZIFFER	I	BEMERKUNGEN	I
			I	1 SITZBANK	I	227365	I	1	1401,406,431,	I		I
			I	2 SITZBANKUNTERTEIL	I	227364	I	1	1401,406,431,	I	IA:MIT ABB. 2,11,13.	I
			I	3 SCHLOSSKOERPER	I	215444	I	1	1401,406,431,	I		I
			I	4 FEDER	I	215446	I	1	1401,406,431,	I		I
			I	5 PLATTE	I	215445	I	1	1401,406,431,	I		I
			I	6 SCHLOSSGEHAEUSE	I	215443	I	1	1401,406,431,	I		I
			I	7 SPERRIEGEL	I	227412	I	1	1401,406,431,	I		I
			I	8 SCHEIBE	I	S 003056	I	2	1401,406,431,	I		I
			I	9 FEDERRING	I	S 016406	I	2	1401,406,431,	I		I
			I	10 SCHRAUBE	I	S 031087	I	2	1401,406,431,	I		I
			I	11 PUFFER	I	217959	I	2	1401,406,431,	I		I
			I	12 ZIERSTREIFEN ROT	I	233278	I	2	1401,406,431,	I		I
			I	12 ZIERSTREIFEN WEISS	I	243540	I	2	1401,406,431,	I		I
			I	13 PUFFER	I	226780	I	2	1401,406,431,	I		I
			I	14 SCHEIBE	I	S 013763	I	8	1401,406,	I		I
			I	14 SCHEIBE	I	S 013769	I	8	1431,	I		I
			I	15 SCHRAUBE	I	S 008451	I	8	1401,406,431,	I		I
			I	16 HALTEBUEGEL	I	227363	I	1	1401,406,431,	I		I
			I	17 SCHRAUBE	I	S 031117	I	4	1431,	I		I
			I	18 FEDERRING	I	S 016408	I	4	1431,	I		I
			I	19 SCHEIBE	I	S 003058	I	4	1431,	I		I
			I	SEITL.ABDECKUNG FUER SITZBANK	I	227165	I	1	1401,406,	I	IB:AB JUNI 1986	I

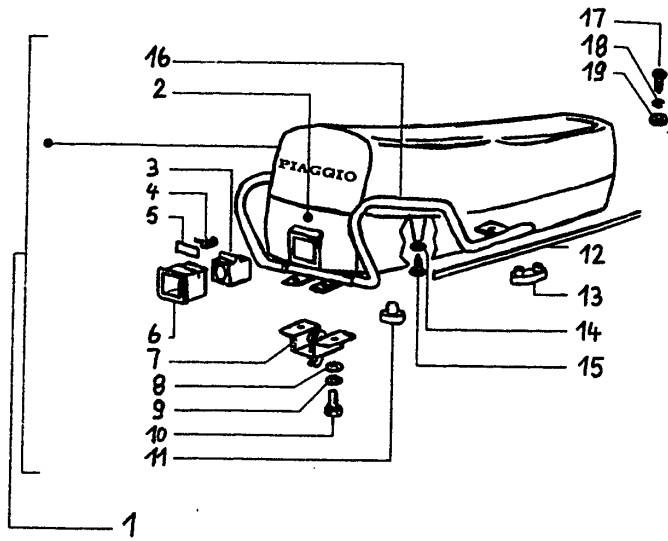

ITAFEL 37 SEITENKLAPPEN

SPALTE 76



ABB.	BENENNUNG	ERSATZTEIL	ST	KENNZIFFER	BEMERKUNGEN
1	SCHRIFTZUG PK 50 XL	I 227488	I 1	I 1401,	I
1	SCHRIFTZUG PK 125 XL	I 227563	I 1	I 1431,	I
2	SCHRIFTZUG PK50XL ELESTART	I 227473	I 1	I 1406,	I
3	FEDERMUTTER	I S 008108	I 2	I 1401,406,431,	I
4	PUFFER	I 226164	I 2	I 1401,406,	I
5	HALTER F. Klappe AM RAHMEN	I 241232	I 2	I 1401,406,431,	I
6	AUFNAHMENIPPEL	I 241235	I 4	I 1401,406,431,	I
7	SEITENKLAPPE RECHTS	I 234516	I 1	I 1401,406,431,	I
8	SEITENKLAPPE LINKS	I 234515	I 1	I 1401,406,431,	I
9	HALTERIEMEN	I 195556	I 1	I 1401,406,431,	I
10	ZUGKNOPF	I 234422	I 2	I 1401,406,431,	I
11	ZUGKNOPFAUFNAHME	I 234421	I 2	I 1401,406,431,	I
12	SEILZUG FUER SEITENKLAPPEN	I 234499	I 2	I 1401,406,431,	I
13	SEILZUGDURCHGANG	I 186084	I 2	I 1401,406,431,	I
14	SEITENKLAPPEN- SCHLIESSUNG	I 234548	I 2	I 1401,406,431,	I
15	BLECHSCHRAUBE	I S 015737	I 4	I 1401,406,431,	I
16	SCHEIBE	I S 003055	I 4	I 1401,406,431,	I
17	HALTER FUER KLAPPE AM RAHMEN	I 241231	I 2	I 1401,406,431,	I
18	GERAEUSCHDAEMM- MATTE	I 277289	I 1	I 1401,406,431,	I
	ABZIEHBILD ROT FUER SEITENKLAPPE LINKS	I 228126	I 1	I 1401,	I IA:FUER SONDER- MODELL
	ABZIEHBILD ROT FUER SEITENKLAPPE RECHTS	I 228127	I 1	I 1401,	I

EN	ITAFEL 39	RESERVERADHALTER-WERKZEUGTASCHE	SPALTE 8B	ITAFEL																																																																																										
EN	ITAFEL 40	STEUERROHRLAGER-LENKSCHLOSSAUFN.	SPALTE 8C	ITAFEL																																																																																										
			<table border="1"> <thead> <tr> <th>ITAFEL</th> <th>BENENNUNG</th> <th>ERSATZTEIL</th> <th>ST</th> <th>IKENNZIFFER</th> <th>IBEMERKUNGEN</th> </tr> </thead> <tbody> <tr> <td>I</td> <td>1 FEDERRING</td> <td>I S 016408</td> <td>I 3</td> <td>I 1401,406,431,</td> <td>I</td> </tr> <tr> <td>I</td> <td>2 SCHRAUBE</td> <td>I S 031115</td> <td>I 3</td> <td>I 1401,406,431,</td> <td>I</td> </tr> <tr> <td>I</td> <td>3 SCHEIBE</td> <td>I S 003058</td> <td>I 3</td> <td>I 1401,406,431,</td> <td>I</td> </tr> <tr> <td>I</td> <td>4 BAJONETT- VESCHLUSS</td> <td>I 132871</td> <td>I 2</td> <td>I 1401,406,431,</td> <td>I</td> </tr> <tr> <td>I</td> <td>5 FEDER</td> <td>I 122957</td> <td>I 2</td> <td>I 1401,406,431,</td> <td>I</td> </tr> <tr> <td>I</td> <td>6 RESERVERADAB- DECKUNG</td> <td>I 216971</td> <td>I 1</td> <td>I 1401,406,431,</td> <td>I</td> </tr> <tr> <td>I</td> <td>7 HALTER</td> <td>I 216316</td> <td>I 1</td> <td>I 1401,406,</td> <td>I</td> </tr> <tr> <td>I</td> <td>7 HALTER</td> <td>I 214818</td> <td>I 1</td> <td>I 1431,</td> <td>I</td> </tr> <tr> <td>I</td> <td>8 FEDERRING</td> <td>I S 016408</td> <td>I 3</td> <td>I 1401,406,431,</td> <td>I</td> </tr> <tr> <td>I</td> <td>9 MUTTER</td> <td>I S 020108</td> <td>I 3</td> <td>I 1401,406,431,</td> <td>I</td> </tr> <tr> <td>I</td> <td>10 RESERVERADHALTER KPL.</td> <td>I 217095</td> <td>I 1</td> <td>I 1401,406,431,</td> <td>IA: MIT ABB. 1- 9</td> </tr> <tr> <td>I</td> <td>11 WERKZEUGSATZ</td> <td>I 195565</td> <td>I 1</td> <td>I 1401,406,431,</td> <td>I</td> </tr> <tr> <td>I</td> <td>12 MESSBECHER</td> <td>I Z 085058</td> <td>I 1</td> <td>I 1401,406,431,</td> <td>I</td> </tr> <tr> <td>I</td> <td>13 LUFTPUMPE</td> <td>I 098464</td> <td>I 1</td> <td>I 1401,406,431,</td> <td>I</td> </tr> </tbody> </table>	ITAFEL	BENENNUNG	ERSATZTEIL	ST	IKENNZIFFER	IBEMERKUNGEN	I	1 FEDERRING	I S 016408	I 3	I 1401,406,431,	I	I	2 SCHRAUBE	I S 031115	I 3	I 1401,406,431,	I	I	3 SCHEIBE	I S 003058	I 3	I 1401,406,431,	I	I	4 BAJONETT- VESCHLUSS	I 132871	I 2	I 1401,406,431,	I	I	5 FEDER	I 122957	I 2	I 1401,406,431,	I	I	6 RESERVERADAB- DECKUNG	I 216971	I 1	I 1401,406,431,	I	I	7 HALTER	I 216316	I 1	I 1401,406,	I	I	7 HALTER	I 214818	I 1	I 1431,	I	I	8 FEDERRING	I S 016408	I 3	I 1401,406,431,	I	I	9 MUTTER	I S 020108	I 3	I 1401,406,431,	I	I	10 RESERVERADHALTER KPL.	I 217095	I 1	I 1401,406,431,	IA: MIT ABB. 1- 9	I	11 WERKZEUGSATZ	I 195565	I 1	I 1401,406,431,	I	I	12 MESSBECHER	I Z 085058	I 1	I 1401,406,431,	I	I	13 LUFTPUMPE	I 098464	I 1	I 1401,406,431,	I	
ITAFEL	BENENNUNG	ERSATZTEIL	ST	IKENNZIFFER	IBEMERKUNGEN																																																																																									
I	1 FEDERRING	I S 016408	I 3	I 1401,406,431,	I																																																																																									
I	2 SCHRAUBE	I S 031115	I 3	I 1401,406,431,	I																																																																																									
I	3 SCHEIBE	I S 003058	I 3	I 1401,406,431,	I																																																																																									
I	4 BAJONETT- VESCHLUSS	I 132871	I 2	I 1401,406,431,	I																																																																																									
I	5 FEDER	I 122957	I 2	I 1401,406,431,	I																																																																																									
I	6 RESERVERADAB- DECKUNG	I 216971	I 1	I 1401,406,431,	I																																																																																									
I	7 HALTER	I 216316	I 1	I 1401,406,	I																																																																																									
I	7 HALTER	I 214818	I 1	I 1431,	I																																																																																									
I	8 FEDERRING	I S 016408	I 3	I 1401,406,431,	I																																																																																									
I	9 MUTTER	I S 020108	I 3	I 1401,406,431,	I																																																																																									
I	10 RESERVERADHALTER KPL.	I 217095	I 1	I 1401,406,431,	IA: MIT ABB. 1- 9																																																																																									
I	11 WERKZEUGSATZ	I 195565	I 1	I 1401,406,431,	I																																																																																									
I	12 MESSBECHER	I Z 085058	I 1	I 1401,406,431,	I																																																																																									
I	13 LUFTPUMPE	I 098464	I 1	I 1401,406,431,	I																																																																																									

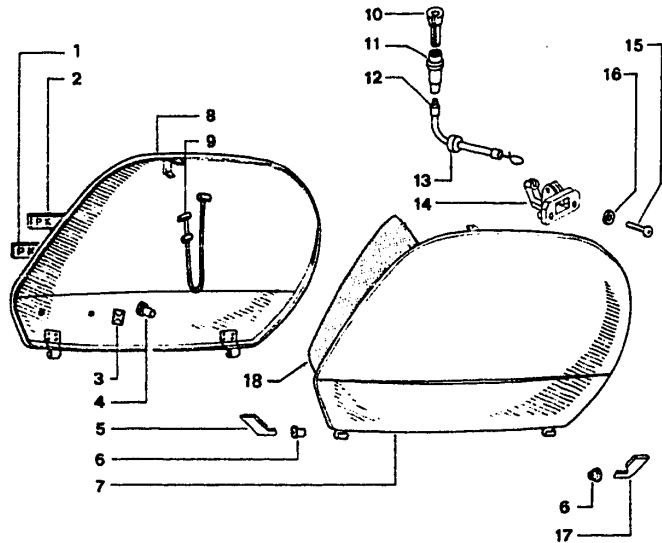
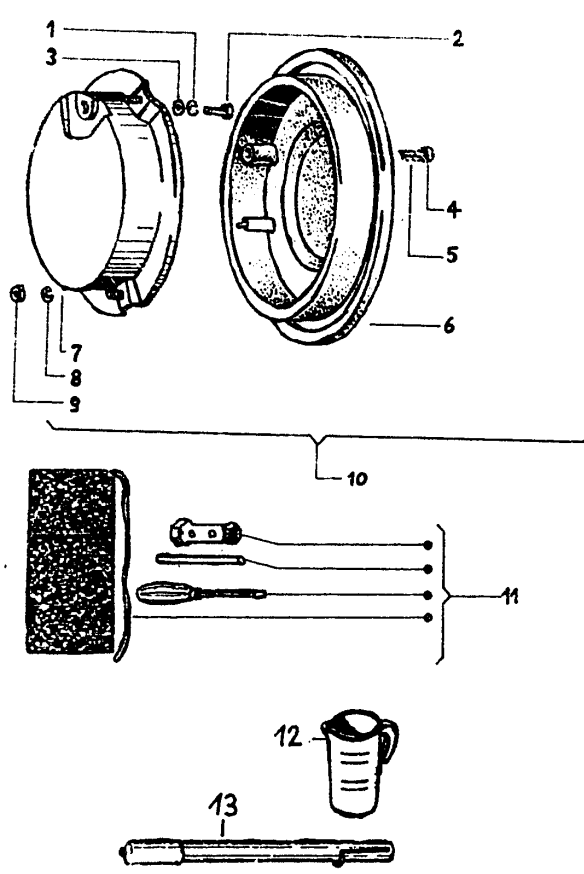

EN	ITAFEL 40	STEUERROHRLAGER-LENKSCHLOSSAUFN.	SPALTE 8C	ITAFEL						
			<table border="1"> <thead> <tr> <th>ITAFEL</th> <th>BENENNUNG</th> <th>ERSATZTEIL</th> <th>ST</th> <th>IKENNZIFFER</th> <th>IBEMERKUNGEN</th> </tr> </thead> </table>	ITAFEL	BENENNUNG	ERSATZTEIL	ST	IKENNZIFFER	IBEMERKUNGEN	
ITAFEL	BENENNUNG	ERSATZTEIL	ST	IKENNZIFFER	IBEMERKUNGEN					

EN	TAFEL 40 STEUERRÖHRLAGER-LENKSCHLOSSAUFN. SPALTE 8C			1	2	3	4	5	6	7	8	9	10	11	12	13	14	15
				1	2	3	4	5	6	7	8	9	10	11	12	13	14	15
				I ABB. BENENNUNG		I ERSATZTEIL	I ST	I KENNZIFFER	I BEMERKUNGEN									
				I	1 OBERER FESTSTELL-	I	1	I401,406,431,	I									
				I	RING	I		I	I									
				I	2 NASENSCHEIBE	I	1	I401,406,431,	I									
				I	3 LAGERSCHALE	I	1	I401,406,431,	I									
				I	4 KUGELKRANZ	I	1	I401,406,431,	I									
				I	5 LAGERSITZ	I	1	I401,406,431,	I									
				I	6 LAGERSCHALE	I	1	I401,406,431,	I									
				I	7 KUGELKRANZ	I	1	I401,406,431,	I									
				I	8 LAGERSCHALE	I	1	I401,406,431,	I									
				I	9 SCHUTZRING	I	1	I401,406,431,	I									
				I	10 FEDERPLÄTTCHEN	I	1	I401,406,431,	I									
				I	11 AUFNAHME FUER SPERRWALZE	I	1	I401,406,431,	I IC: SCHLOSSZYLIND. I TAFEL 34.									
				I	12 SPERRWALZE	I	1	I401,406,431,	I									
				I	13 SCHLOSSKOERPER	I	1	I401,406,431,	I									
				I	14 LAGERSATZ	I	1	I401,406,431,	I									
				I	15 LAGERSATZ	I	1	I401,406,431,	I IB: MIT ABB. 1 - 5I IA: MIT ABB. 7 - 9I									

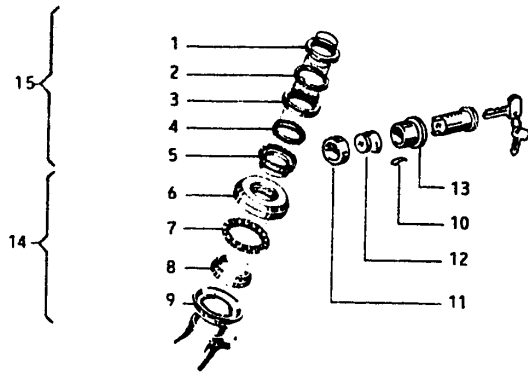

N	TAFEL 41 GERÄUSCHDAEMMATTEN F. KAROSSERIE SPALTE 8D			1	2	3	4	5	6	7	8	9	10	11	12	13	14	15
				I ABB. BENENNUNG		I ERSATZTEIL	I ST	I KENNZIFFER	I BEMERKUNGEN									

ITAFEL 43

STEUERROHR

SPALTE 8F

I ABB. BENENNUNG I ERSATZTEIL I ST IKENNZIFFER I IBEMERKUNGEN I

,3,4

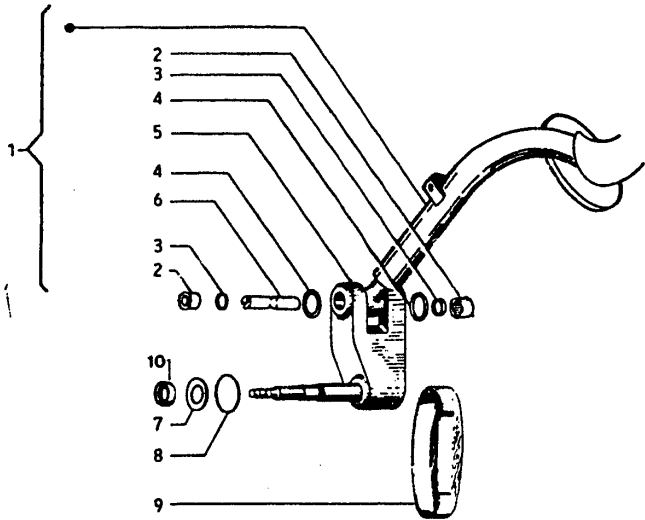

I ABB. BENENNUNG I	I ERSATZTEIL I	I ST IKENNZIFFER I	I IBEMERKUNGEN I
I 1 STEUERRÖHR KPL. I	I 216245 I	I 1 I401,406,431, I	I IA:MIT ABB. 2 - 6I
I 2 NADELLAGER I	I 198513 I	I 2 I401,406,431, I	I I I I
I 3 RING I	I 119219 I	I 2 I401,406,431, I	I I I I
I 4 DICHRING I	I S 006731 I	I 2 I401,406,431, I	I I I I
I 5 VORDERRADSWINGE I	I 178051 I	I 1 I401,406,431, I	I I I I
I 6 BOLZEN I	I 177451 I	I 1 I401,406,431, I	I I I I
I 7 U.-SCHEIBE I	I 177445 I	I 1 I401,406,431, I	I I I I
I 8 RING I	I 177408 I	I 1 I401,406,431, I	I I I I
I 9 DECKEL I	I 216985 I	I 1 I401,406,431, I	I I I I
I 10 RING I	I 177521 I	I 1 I401,406,431, I	I I I I

UNGEN	ITAFEL 46	VORDERRADBREMSTROMMEL	SPALTE 9C	I ABB. BENENNUNG	I ERSATZTEIL	I ST IKENNZIFFER	I BEMERKUNGEN	ITAFEL
				1 FEDERRING	S 016408	5 1401,406,431,		
				2 MUTTER	S 020108	5 1401,406,431,		
				3 SEEGERRING	S 006635	1 1401,406,431,		
				4 KUGELLAGER	177610	1 1401,406,431,		
				5 SCHRAUBBOLZEN	085914	5 1401,406,431,		
				6 NADELKAEFIG	177442	1 1401,406,431,		
				7 DICHTRING	177443	1 1401,406,431,		
				8 U.-SCHEIBE	177414	1 1401,406,431,		
				9 FEDERRING	S 006422	1 1401,406,431,		
				10 BREMSTROMMEL	215994	1 1401,406,431,		
				11 MUTTER	S 021114	1 1401,406,431,		
				12 SICHERUNGSKAPPE	177609	1 1401,406,431,		
				13 SPLINT	S 012789	1 1401,406,431,		
				14 DECKEL	215917	1 1401,406,431,		
							IA:MIT ABB. 3 - 7	

OSSZYLIND.
L 34.

ABB. 1 - 5
ABB. 7 - 9

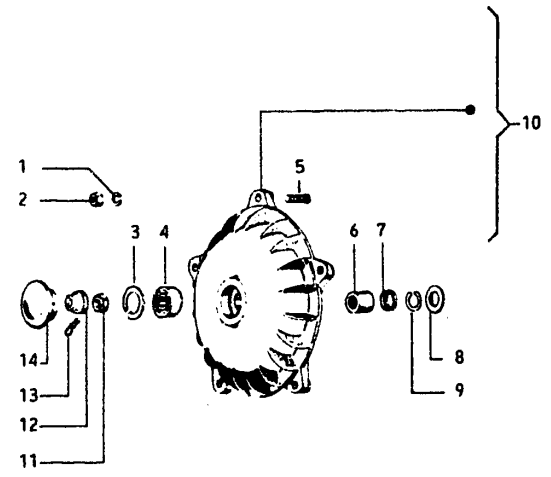

UNGEN	ITAFEL 47	STOSSDAEMPFER VORNE	SPALTE 9D	I ABB. BENENNUNG	I ERSATZTEIL	I ST IKENNZIFFER	I BEMERKUNGEN	ITAFEL
-------	-----------	---------------------	-----------	------------------	--------------	------------------	---------------	--------

JNGEN	TAFEL 47	STOSSDAEMPFER VORNE	SPALTE 9D	IABB. BENENNUNG	ERSATZTEIL	ST IKENNZIFFER	IBEMERKUNGEN	TAFEL
				1 MUTTER	S 021210	1 1401,406,431,		
				2 FEDERRING	S 016410	1 1401,406,431,		
				3 SCHEIBE	174088	1 1401,406,431,		
				4 SCHRAUBE	S 031119	2 1401,406,431,		
				5 PUFFER	216209	2 1401,406,431,		
				6 HALTER	225748	1 1401,406,431,		
				7 FEDERRING	S 016408	4 1401,406,431,		
				8 MUTTER	S 020108	4 1401,406,431,		
				9 SCHRAUBE	S 030074	2 1401,406,431,		
				10 OBERE PLATTE	216234	1 1401,406,431,		
				11 STOSSDAEMPFER- ABDECKUNG	216231	1 1401,406,431,		
				12 PUFFER	216233	1 1401,406,431,		
				13 STOSSDAEMPFER- FEDER	198286	1 1401,406,431,		
				14 AUESSERES STOSS- DAEMPFER ROHR	216229	1 1401,406,431,		
				15 SCHEIBE	225743	1 1401,406,431,		
				16 STOSSDAEMPFER	225739	1 1401,406,431,		
					A		IA:MIT ABB.10-15	

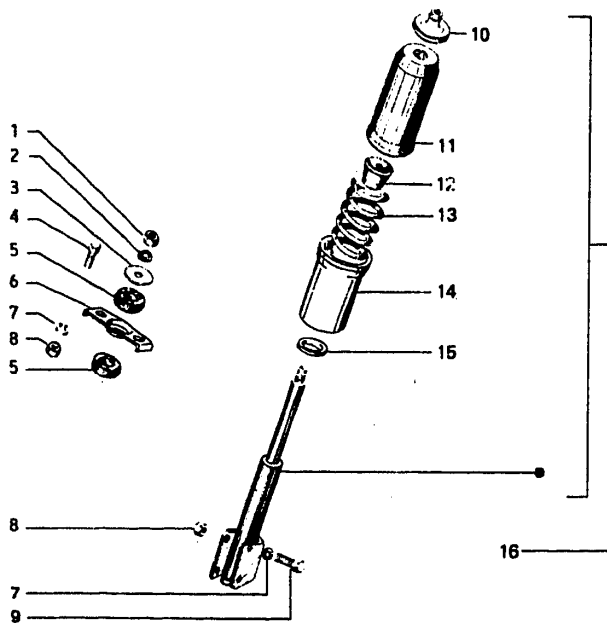

JNGEN	TAFEL 48	STOSSDAEMPFER HINTEN	SPALTE 9E	IABB. BENENNUNG	ERSATZTEIL	ST IKENNZIFFER	IBEMERKUNGEN	TAFEL
				1 MUTTER	S 020200	1 1401,406,431,		

NGEN	I	I	TAFEL 48	STOSSDAEMPFER HINTEN	SPALTE 9E	ABB. BENENNUNG	I	ERSATZTEIL	I	ST	IKENNZIFFER	IBEMERKUNGEN	I	I	TAFEL
	I	I				1 MUTTER	I	S 020209	I	1	1401,406,431,	I	I	I	
	I	I				2 FEDERRING	I	S 016409	I	1	1401,406,431,	I	I	I	
	I	I				3 PLATTE	I	178152	I	1	1401,406,431,	I	I	I	
	I	I				4 PUFFER	I	178150	I	1	1401,406,431,	I	I	I	
	I	I				5 PUFFER	I	178149	I	1	1401,406,431,	I	I	I	
	I	I				6 MUTTER	I	S 020109	I	1	1401,406,431,	I	I	I	
	I	I				7 STOSSDAEMPFERROHRE	I	178145	I	1	1401,406,431,	I	I	I	
	I	I				8 UNTERE AUFNAHME	I	240272	I	1	1401,406,	I	I	I	
	I	I				9 GUMMIPUFFER	I	178144	I	1	1401,406,431,	I	I	I	
	I	I				10 STOSSDAEMPFER HINTEN KPL.	I	240267	I	1	1401,406,	I	I	I	
	I	I				10 STOSSDAEMPFER HINTEN KPL.	I	240214	I	1	1431,	I	I	I	
	I	I				11 STOSSDAEMPFER-FEDER	I	179108	I	1	1401,406,431,	I	I	I	
	I	I				12 FEDERRING	I	S 016410	I	1	1401,406,431,	I	I	I	
	I	I				13 MUTTER	I	S 020210	I	1	1401,406,431,	I	I	I	
	I	I				14 SCHRAUBE	I	S 030103	I	1	1401,406,431,	I	I	I	

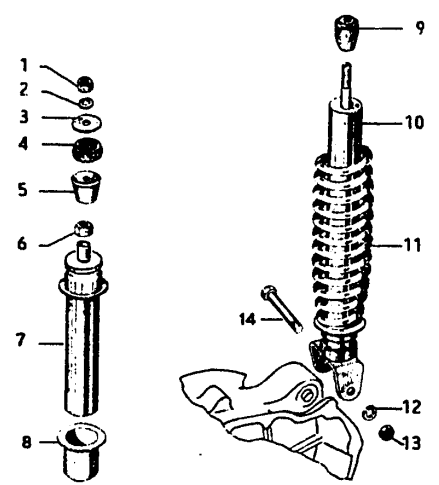

SONDER-

INGEN

TAFEL 49

LENKER - SPIEGEL

SPALTE 10A

ABB. BENENNUNG I ERSATZTEIL I ST IKENNZIFFER I BEMERKUNGEN I

BB. 7,8.

BB. 10



ABB. BENENNUNG	ERSATZTEIL	ST	IKENNZIFFER	BEMERKUNGEN
2 SCHRAUBE	S 031119	2	I401,406,431,	
3 SCHEIBE	S 012538	2	I401,406,431,	
5 SPIEGEL	090845	1	I401,406,431,	IA: MIT ABB. 1 - 4I
5 SPIEGEL	244141	1	I401,406,431,	IB: MIT ABB. DER TAF. 50, 51, 52.
6 LENKER KPL.	227117	1	I401,406,431,	
6 LENKER KPL.	244213	1	I401,406,431,	IC: GUELTIG FUER
7 HALTER FUER SPIEGEL IM LENKER	244125	1	I401,406,431,	ROLLER MIT SCHWARZEM QUADRATISCHEM SPIEGEL, DER DIREKT IM LENKER MONTIERT WIRD.
8 FEDERSCHEIBE FUER SPIEGELHALTER	S 007609	1	I401,406,431,	
9 DICHTUNG FUER SPIEGELHALTER	244126	1	I401,406,431,	
10 MUTTER FUER SPIEGELHALTER	227673	1	I401,406,431,	
11 ABDECKKAPPE FUER SPIEGELHALTER	125998	1	I401,406,431,	

NGEN	ITAFEL 50	LENKERGEHAEUSE	SALTE 10B	IABB. BENENNUNG	I ERSATZTEIL	I ST IKENNZIFFER	IBEMERKUNGEN	I	I
				1 LENKEROBERTEIL	226730	1 1401,406,431			
				1 LENKEROBERTEIL MIT OEFFNUNG FUER SPIEGEL	244205	1 1401,406,431	IA:GUELTIG FUER ROLLER MIT SCHWARZEM QUADRATISCHEM		
				2 LENKERUNTERTEIL	217350	1 1401,406,431	SPIEGEL, DER DIREKT IM LENKER		
				3 BEF.-SCHRAUBE	S 015542	1 1401,406,431	MONTIERT WIPD.		
				4 MUTTER	070620	1 1401,406,431			
				5 FUEHRUNGSBUCHSE FUER SCHALTZUG	139913	1 1401,406,431			
				6 SCHEIBE	S 003055	4 1401,406,431			
				7 SCHRAUBE	S 015597	4 1401,406,431			

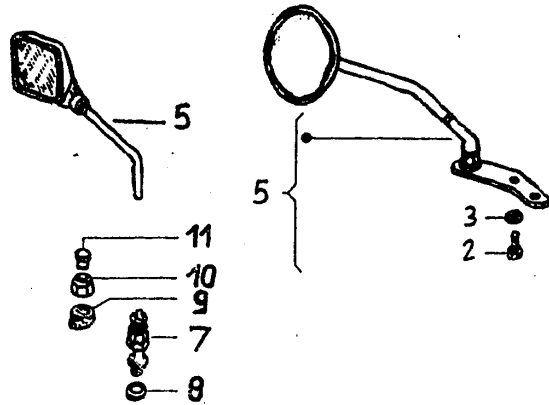
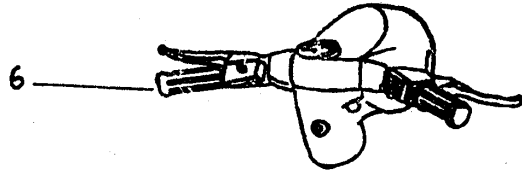
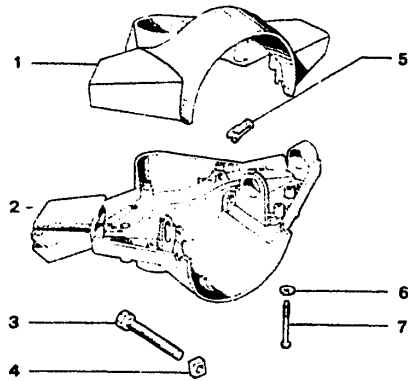

NGEN	ITAFEL 51	GASDREHGRIFF	SALTE 10C	IABB. BENENNUNG	I ERSATZTEIL	I ST IKENNZIFFER	IBEMERKUNGEN	I	I
------	-----------	--------------	-----------	-----------------	--------------	------------------	--------------	---	---

IGEN	TAFEL 51	GASDREHGRIFF	SPALTE 10C	IABB. BENENNUNG	I ERSATZTEIL	I ST	IKENNZIFFER	IBEMERKUNGEN	ITAF
				1 GUMMIGRIFF	227077	1	1401,406,431,		
				2 GASDREHGRIFF	139778	1	1401,406,431,		
				3 BREMSHEBEL	178705	1	1401,406,431,		
				3 BREMSHEBEL	244336	1	1401,406,	IA:AB AUGUST 1986I	
				4 FEDERKLAMMER	137267	1	1401,406,431,		
				5 SCHEIBE	101473	1	1401,406,431,		
				6 SCHEIBE	101474	1	1401,406,431,		
				7 GASZUGFUEHRUNG	139797	1	1401,406,431,		
				8 FUEHRUNGSBUCHSE	139912	1	1401,406,431,		
				9 SCHRAUBE	S 018517	1	1401,406,431,		
				10 WELLSCHLEIBE	017492	1	1401,406,431,		
				11 MUTTER	195482	1	1401,406,431,		
				12 AUFNAHMENIPPEL	178709	1	1401,406,431,		

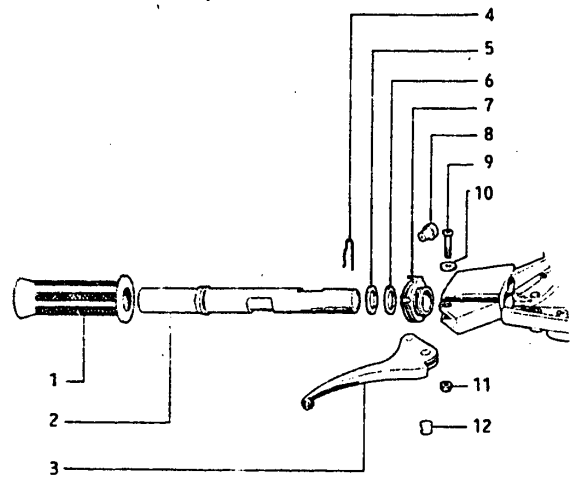

B. 3 - 7

IGEN	TAFEL 52	SCHALTDREHGRIFF	SPALTE 10D	IABB. BENENNUNG	I ERSATZTEIL	I ST	IKENNZIFFER	IBEMERKUNGEN	ITAF
------	----------	-----------------	------------	-----------------	--------------	------	-------------	--------------	------

EN	TAFEL 53	TACHOMETER - KONTROLLEUCHTEN	SPALTE 10E	ABB. BENENNUNG	ERSATZTEIL	ST	IKENNZIFFER	IBEMERKUNGEN	ITAFEL
				1 TACHOWELLE KPL.	195407	1	1401,406,431,		
				2 TACHOSEELE	195409	1	1401,406,431,	IA:MIT ABB. 2	
				3 DICHTUNG	179230	1	1401,406,431,		
				4 SOFITTE	164634	4	1401,406,431,		
				5 FASSUNG	217900	4	1401,406,431,		
				6 TACHOMETER	226739	1	1401,406,		
				6 TACHOMETER	198424	1	1431,	IB:MIT ABB. 3 - 5I	

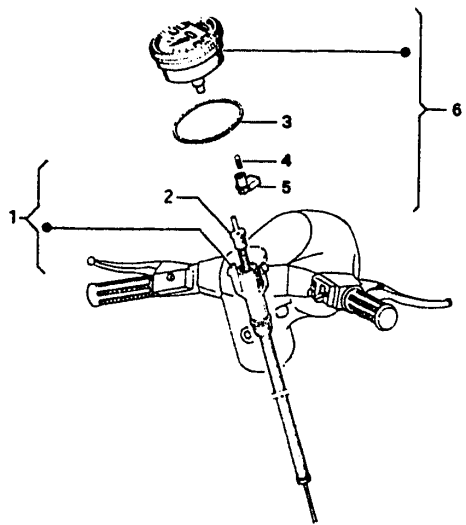

GEN	ITAFEL 55	SCHALTZUG - HINTERRADBREMSZUG	SPALTE 11B	IABB. BENENNUNG	ERSATZTEIL	ST	IKENNZIFFER	IBEMERKUNGEN
3 FUER MIT ZEM FISCHEM DER IM RT WIPD.				1 HINTERRADBREMSZUGI KPL.	191820	1	1401,406,431,	IA:MIT ABB. 2
				2 HINTERRADBREMS- SEIL	191803	1	1401,406,431,	
				3 SCHALTZUG KPL.	195396	2	1401,406,431,	IB:MIT ABB. 4
				4 SCHALTSEIL	195397	2	1401,406,431,	
				5 HALTEBAND	152210	1	1401,406,431,	
				6 KLEMMNIPPEL	153198	2	1401,406,431,	
				7 GUMMIBUCHSE	241071	1	1401,406,431,	

Hinterrad - Bremszug.

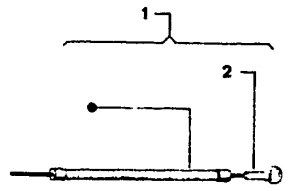

Schaltzug.

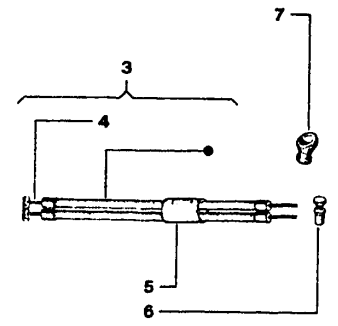

EN	ITAFEL 56	KUPPLUNGSZUG - GASZUG	SPALTE 11C	IABB. BENENNUNG	ERSATZTEIL	ST	IKENNZIFFER	IBEMERKUNGEN
----	-----------	-----------------------	------------	-----------------	------------	----	-------------	--------------

IN	ITAFEL 57	VORDERRADBREMSEZUG - STARTERZUG	SPALTE 11D	IABB. BENENNUNG	I ERSATZTEIL	I ST	IKENNZIFFER	IBEMERKUNGEN
				1 BREMSZUG VORNE KPL.	225037	1	1401,406,431,	
				2 GUMMIMUFFE	179651	1	1401,406,431,	
				3 STARTERZUGSEIL	070884	1	1401,406,431,	
				4 STARTERZUG KPL.	098221	1	1401,406,431,	IB:MIT ABB. 3
				5 STARTERZUGSTANGE	214280	1	1401,406,431,	
				6 MUTTER	195482	1	1401,406,431,	
				7 HEBEL	078305	1	1401,406,431,	
				8 SCHEIBE	078307	1	1401,406,431,	
				9 SCHRAUBE	076306	1	1401,406,431,	

T 1986

Vorderrad - Bremszug.

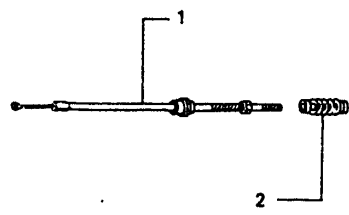

Starterzug

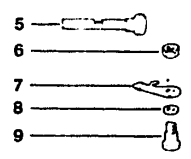
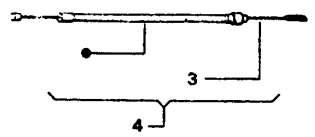

IN	ITAFEL 58	SCHEINWERFER - RUECKLEUCHE	SPALTE 11E	IABB. BENENNUNG	I ERSATZTEIL	I ST	IKENNZIFFER	IBEMERKUNGEN
----	-----------	----------------------------	------------	-----------------	--------------	------	-------------	--------------

I TAFEL 59 HUPE, LICHT-U.BLINKLICHTSCHALTER SPALTE 11F

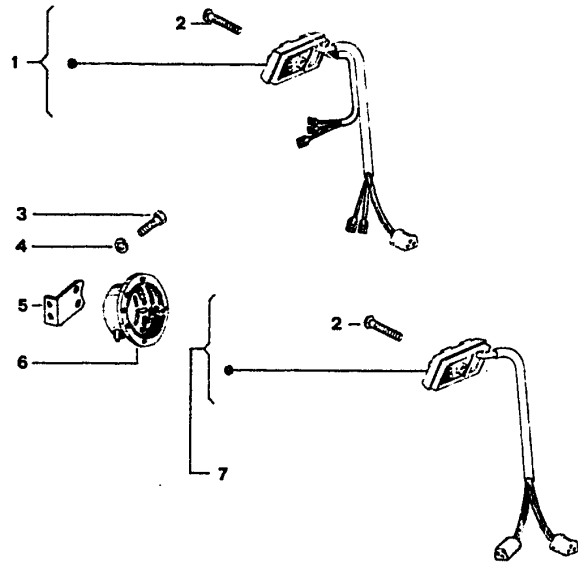

I ABB. BENENNUNG	I ERSATZTEIL	I ST	I KENNZIFFER	I BEMERKUNGEN
I 1 LICHTSCHALTER KPLI	I 231852	I 1	I I401,406,431,	I IA:MIT ABB. 2
I 2 SCHRAUBE	I S 018503	I 2	I I401,406,431,	I
I 3 SCHRAUBE	I S 031086	I 2	I I401,406,431,	I
I 4 FEDERRING	I S 016406	I 2	I I401,406,431,	I
I 5 HALTER	I 231322	I 1	I I401,406,431,	I
I 6 HUPE	I 234365	I 1	I I401,431,	I
I 6 HUPE	I 231320	I 1	I I406,	I
I 7 BLINKLICHTSCHALTER	I 231849	I 1	I I401,406,431,	I

I TAFEL 60 ZUENDSCHLOSS-ANL.KNOPF-SCHALTER SPALTE 11G

ABB.	BENENNUNG	ERSATZTEIL	ST	KENNZIFFER	IBEMERKUNGEN
1	KABELSTRANG FUER SICHERHEITS-SCHALTER	219343	1	1406,	
2	SICHERHEITS-SCHALTER	219337	1	1406,	
3	ZUENDSCHALTER	178593	1	1401,431,	
3	ZUENDSCHALTER	231024	1	1406,	
4	MADENSCHRAUBE	S 018515	1	1401,406,431,	
5	SCHRAUBE	S 018527	2	1406,	
6	ANLASSERKNOPF	217316	1	1406,	

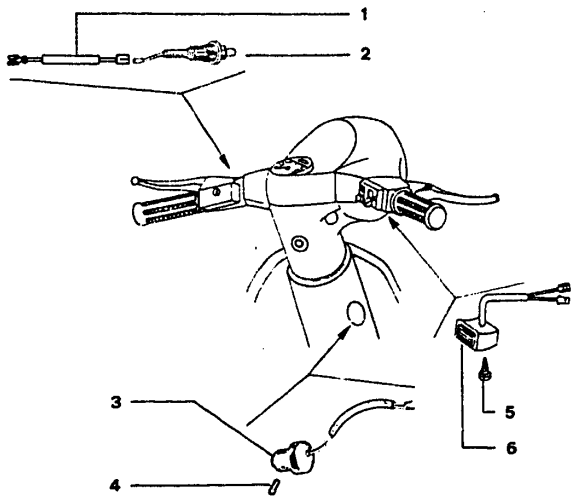

TAFEL 61	REGLER-GLEICHRICHTER-BLINKGEBER	SPALTE 11H	I ABB. BENENNUNG	I ERSATZTEIL	I ST IKENNZIFFER	I BEMERKUNGEN
			1 MUTTER	191962	2 1401,431,	
			2 FEDERRING	S 016406	2 1401,431,	
			3 HALTER	234284	1 1401,431,	
			4 MUTTER	182872	2 1401,431,	
			5 SCHEIBE	S 003056	2 1401,431,	
			6 SCHRAUBE	S 015759	2 1401,431,	
			7 SCHRAUBE	S 008375	2 1401,431,	
			8 FEDERRING	S 016406	2 1401,431,	
			9 SCHRAUBE	S 031089	2 1401,406,431,	
			10 ZAHNSCHEIBE	S 012533	2 1401,406,431,	
			11 ELEKTRON.REGLER	161639	1 1401,431,	
			11 ELEKTRON.REGLER	230824	1 1406,	
			12 SCHRAUBE	S 031033	1 1401,406,431,	
			13 FEDERRING	S 016404	1 1401,406,431,	
			14 SCHEIBE	S 003054	1 1401,406,431,	
			15 STOPLICHT-SCHALTER	181881	1 1401,406,431,	
			16 GU-DICHTUNG	070144	1 1401,406,431,	
			17 ELAST. HALTERUNG	187769	1 1401,406,431,	
			18 BLINKGEBER	197283	1 1406,	
			18 BLINKGEBER	195703	1 1401,431,	
			19 HALTERUNG	215960	1 1401,406,431,	
			20 MUTTER	182872	2 1401,406,431,	
			21 GLEICHRICHTER FUER HUPE	217035	1 1401,431,	

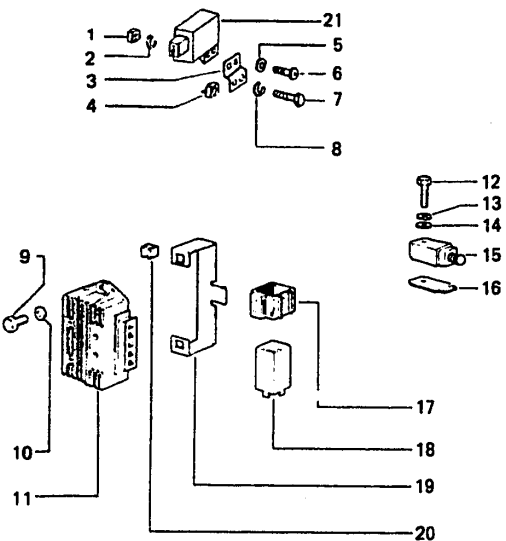

TAFEL 62	KABELBAUM	SPALTE 11I	I ABB. BENENNUNG	I ERSATZTEIL	I ST IKENNZIFFER	I BEMERKUNGEN
			1 KABELBAUM	243483	1 1401,	
			1 KABELBAUM	234252	1 1431,	
			1 KABELBAUM	243485	1 1406,	
			2 LENKERKABELAST	217989	1 1401,406,431,	
			3 KABELDURCHGANG	216789	2 1401,406,431,	
			4 KABELDURCHGANG	234259	1 1401,406,431,	

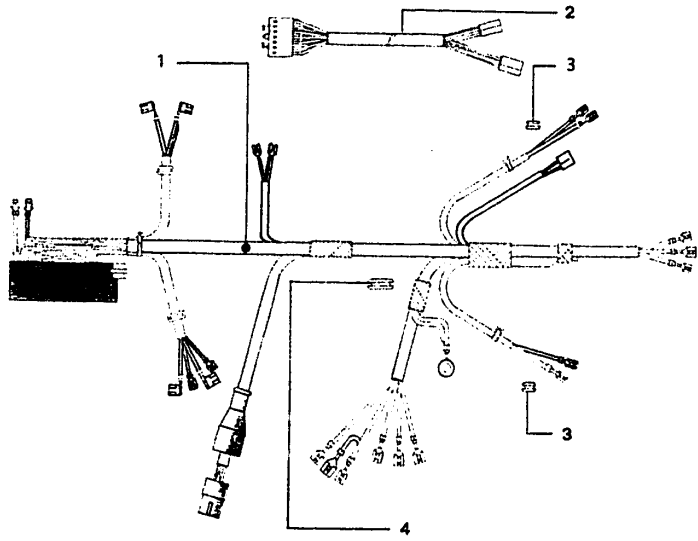

TAFEL 63	BLINKLEUCHTEN VORNE	SPALTE 11J	I ABB. BENENNUNG	I ERSATZTEIL	I ST IKENNZIFFER	I BEMERKUNGEN
----------	---------------------	------------	------------------	--------------	------------------	---------------

ITAFEL 63	BLINKLEUCHTEN VORNE	SPALTE 11J	IABB. BENENNUNG	I ERSATZTEIL	I ST IKENNZIFFER	IBEMERKUNGEN
			1 BLINKLEUCHTE KPL. RECHTS	233971	1 1401,406,	
			1 BLINKLEUCHTE KPL. RECHTS	216783	1 1431,	
			1 BLINKLEUCHTE KPL. LINKS	233970	1 1401,406,	IA:MIT ABB.2,3,4
			1 BLINKLEUCHTE KPL. LINKS	216782	1 1431,	
			2 SCHRAUBE	S 015996	4 1401,406,	
			2 SCHRAUBE	S 015964	4 1431,	
			3 BLINKLICHTKAPPE RECHTS	234772	1 1401,406,	
			3 BLINKLICHTKAPPE RECHTS	217558	1 1431,	
			3 BLINKLICHTKAPPE LINKS	234769	1 1401,406,	
			3 BLINKLICHTKAPPE LINKS	217557	1 1431,	
			4 LAMPE 12V-10W	181746	2 1401,406,431,	
			5 MUTTER	216819	4 1401,406,431,	

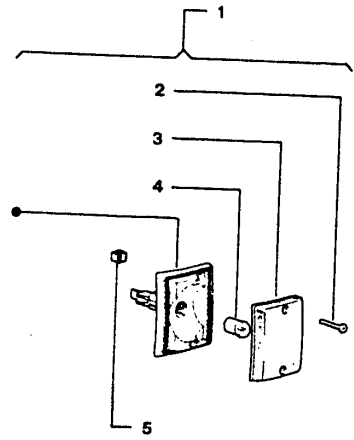

ITAFEL 64	BLINKLEUCHTEN HINTEN	SPALTE 11K	IABB. BENENNUNG	I ERSATZTEIL	I ST IKENNZIFFER	IBEMERKUNGEN
-----------	----------------------	------------	-----------------	--------------	------------------	--------------

ITAFEL 64	BLINKLEUCHTEN HINTEN	SPALTE 11K	I	ABB. BENENNUNG	I	ERSATZTEIL	I	ST	IKENNZIFFER	IBEMERKUNGEN	I
			I	1 BLINKLEUCHTE KPL. RECHTS	I	234065	I	1	1401,406,	IA:MIT ABB.2,3,4	I
			I	1 BLINKLEUCHTE KPL. RECHTS	I	216785	I	1	1431,		I
			I	1 BLINKLEUCHTE KPL. LINKS	I	234061	I	1	1401,406,		I
			I	1 BLINKLEUCHTE KPL. LINKS	I	216784	I	1	1431,		I
			I	2 LAMPE 12V-10W	I	181746	I	2	1401,406,431,		I
			I	3 BLINKLICHTKAPPE RECHTS	I	234778	I	1	1401,406,		I
			I	3 BLINKLICHTKAPPE RECHTS	I	217547	I	1	1431,		I
			I	3 BLINKLICHTKAPPE LINKS	I	234774	I	1	1401,406,		I
			I	3 BLINKLICHTKAPPE LINKS	I	217546	I	1	1431,		I
			I	4 SCHRAUBE	I	S 015996	I	4	1401,406,		I
			I	4 SCHRAUBE	I	S 008999	I	4	1431,		I
			I	5 MUTTER	I	216819	I	4	1401,406,431,		I

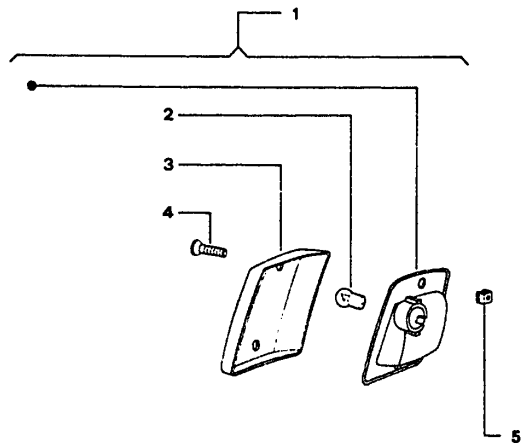

ITAFEL 65	BATTERIE-FERNSCHALTER-ELESTART	SPALTE 11L	I	ABB. BENENNUNG	I	ERSATZTEIL	I	ST	IKENNZIFFER	IBEMERKUNGEN	I
-----------	--------------------------------	------------	---	----------------	---	------------	---	----	-------------	--------------	---

TAFEL 66	REIFEN - FELGE	SPALTE 11M	I ABB. BENENNUNG	I ERSATZTEIL	I ST	I KENNZIFFER	I BEMERKUNGEN
			1 BOLZEN	I 139466	I 10	I 1401,406,431,	I
			2 FELGENHAELFTE	I 084630	I 2	I 1401,406,431,	IA:MIT ABB. 1
			3 SCHLAUCH	I 240241	I 2	I 1401,406,431,	I
			4 FELGE KPL.	I 084631	I 2	I 1401,406,431,	IB:MIT ABB. 2 - 8
			5 REIFEN 3.00-10	I 158701	I 2	I 1401,406,	I
			5 REIFEN 3.00-10 REINFORCED	I 191900	I 2	I 1431,	I
			6 FELGENHAELFTE	I 084629	I 2	I 1401,406,431,	I
			7 FEDERRING	I S 016408	I 10	I 1401,406,431,	I
			8 MUTTER	I S 020108	I 10	I 1401,406,431,	I
			9 RADZIERKAPPE	I 233193	I 2	I 1401,406,431,	ID:NICHT SERIEN- MAESSIG MONT.
			9 RADZIERKAPPE	I 446012	I 2	I 1401,	I
			10 RAD KPL.	I 100496	I 2	I 1401,406,	I
			10 RAD KPL.	I 193300	I 2	I 1431,	IC:MIT ABB. 3 - 5
			11 FEDERHALTER FUER RADZIERKAPPE	I 233194	I 10	I 1401,406,431,	I
			PFROPFEN FUER RADZIERKAPPE	I 446013	I 2	I 1401,	IE:FUER SONDER- MODELL
			DISTANZMUTTER F. RADZIERKAPPE	I 446014	I 10	I 1401,	I
			INBUSSCHRAUBE F. RADZIERKAPPE	I 446094	I 10	I 1401,	I
			RADZIERKAPPENSET (MIT PFROPFEN, DISTANZMUTTERN U. INBUSSCHRAUBENI	I 446091	I 1	I 1401,	I

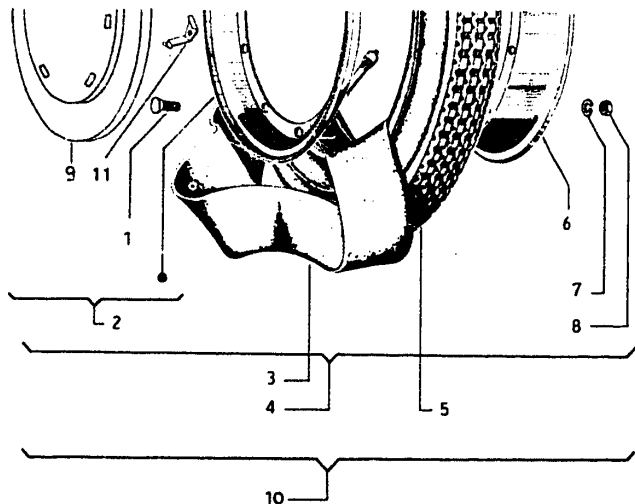

ERSATZTEIL - NUMMERN - VERZEICHNIS									
ITEILE-NR.	SPALTE	TEILE-NR.	SPALTE	TEILE-NR.	SPALTE	TEILE-NR.	SPALTE	TEILE-NR.	SPALTE
I		I		I		I		I	
I		I		I		I		I	
I		I		I		I		I	
I	179487	I	195565	I	215937	I	219002	I	227678
I	179568	I	195629	I	215960	I	219336	I	227679
I	179569	I	195703	I	215993	I	219337	I	227680
I	179574	I	196342	I	215994	I	219343	I	227857
I	179575	I	196345	I	216140	I	219365	I	227914
I	179640	I	196467	I	216142	I	219383	I	228126
I	179641	I	196486	I	216209	I	219415	I	228127
I	179651	I	196549	I	216229	I	219528	I	230824
I	179753	I	196694	I	216231	I	221813	I	230862
I	179754	I	196758	I	216233	I	222209	I	230872
I	179755	I	196759	I	216234	I	222428	I	230951
I	179756	I	196760	I	216245	I	222429	I	230965
I	179757	I	196767	I	216247	I	223392	I	231005
I	179758	I	196774	I	216255	I	223602	I	231007
I	179810	I	196775	I	216256	I	223603	I	231024
I	180200	I	196776	I	216306	I	223604	I	231078
I	180470	I	196931	I	216316	I	224587	I	231095
I	181746	I	197072	I	216486	I	224671	I	231241
I	181747	I	197073	I	216782	I	224672	I	231242
I	181881	I	197283	I	216783	I	224755	I	231243
I	182049	I	197411	I	216784	I	224781	I	231243
I	182051	I	197999	I	216785	I	224788	I	231320
I	182541	I	198027	I	216789	I	224998	I	231322
I	182872	I	198122	I	216819	I	225034	I	231571
I		I	198152	I	216895	I	225037	I	231589
I	183124	I	198286	I	216918	I	225739	I	231849
I	183774	I	198424	I	216971	I	225743	I	231852
I	183980	I	198513	I	216983	I	225748	I	233120
I	185606	I	199055	I	216984	I	226164	I	233121
I	186084	I	199091	I	216985	I	226726	I	233122
I	187769	I	199190	I	217035	I	226730	I	233193
I	191642	I	199258	I	217095	I	226739	I	233194
I	191803	I	199454	I	217128	I	226745	I	233278
I	191820	I	199495	I	217154	I	226754	I	233970
I	191900	I	199603	I	217246	I	226780	I	233971
I	191962	I	199806	I	217252	I	226890	I	234004
I	192353	I	199915	I	217253	I	226980	I	234061
I	193300	I	199922	I	217316	I	227077	I	234065
I	193878	I	199924	I	217350	I	227117	I	234171
I	194380	I	199092	I	217352	I	227165	I	234172
I	194423	I	214280	I	217403	I	227300	I	234225
I	194424	I	214512	I	217421	I	227363	I	234252
I	195388	I	214818	I	217546	I	227364	I	234259
I	195389	I	215443	I	217547	I	227365	I	234260
I	195396	I	215444	I	217557	I	227412	I	234281
I	195397	I	215445	I	217558	I	227473	I	234284
I	195407	I	215446	I	217618	I	227488	I	234322
I	195409	I	215514	I	217900	I	227563	I	234351
I	195482	I	215917	I	217959	I	227673	I	234353
I	195556	I	215934	I	217989	I	227677	I	234355
I		I		I		I		I	
I		I		I		I		I	
I		I		I		I		I	

E R S A T Z T E I L - N U M M E R N - V E R Z E I C H N I S									
TEILE-NR.	SPALTE	TEILE-NR.	SPALTE	TEILE-NR.	SPALTE	TEILE-NR.	SPALTE	TEILE-NR.	SPALTE
I		I		I		I		I	
I	234365	I	243473	I	I S 005771	I	I S 012563	I	I S 018534
I	234411	I	243483	I	I S 005772	I	I S 012761	I	I S 020005
I	234421	I	243485	I	I S 005901	I	I S 012789	I	I S 020006
I	234422	I	243540	I	I S 005962	I	I S 013010	I	I S 020105
I	234498	I	244125	I	I S 006018	I	I S 013763	I	I
I	234499	I	244126	I	I S 006125	I	I S 013769	I	I S 020106
I	234515	I	244141	I	I S 006379	I	I S 013940	I	I
I	234516	I	244205	I	I S 006422	I	I S 015123	I	I S 020107
I	234548	I	244213	I	I S 006425	I	I S 015252	I	I
I	234682	I	244336	I	I S 006612	I	I S 015317	I	I S 020108
I	234769	I	244337	I	I S 006615	I	I S 015507	I	I
I	234772	I	244347	I	I S 006635	I	I S 015510	I	I S 020109
I	234774	I	244348	I	I S 006647	I	I S 015523	I	I S 020207
I	234778	I	244355	I	I S 006706	I	I S 015542	I	I S 020209
I	235598	I	244364	I	I S 006708	I	I S 015559	I	I S 020210
I	235606	I	244365	I	I S 006716	I	I S 015585	I	I S 021112
I	235607	I	244524	I	I S 006721	I	I	I	I S 021114
I	235608	I	244588	I	I S 006731	I	I S 015597	I	I S 021210
I	235648	I	245197	I	I S 006965	I	I S 015598	I	I S 030034
I	235649	I	245449	I	I S 006966	I	I S 015715	I	I S 030050
I	235650	I	253181	I	I S 006975	I	I S 015729	I	I S 030074
I	235651	I	277289	I	I S 007035	I	I S 015737	I	I S 030081
I	230885	I	307166	I	I S 007125	I	I	I	I S 030103
I	240104	I	309652	I	I S 007130	I	I S 015759	I	I S 031027
I	240214	I	445165	I	I S 007608	I	I S 015901	I	I S 031033
I	240241	I	446012	I	I S 007609	I	I S 015932	I	I S 031056
I	240267	I	446013	I	I S 008108	I	I S 015946	I	I S 031058
I	240272	I	446014	I	I S 008112	I	I S 015964	I	I S 031084
I	240452	I	446091	I	I S 008230	I	I S 015994	I	I S 031086
I	240753	I	446094	I	I S 008265	I	I S 015996	I	I S 031087
I	241037	I	I S 000456	I	I S 008372	I	I S 016036	I	I S 031088
I	241071	I	I S 000480	I	I S 008375	I	I S 016335	I	I S 031089
I	241231	I	I S 000584	I	I S 008419	I	I S 016404	I	I S 031091
I	241232	I	I S 000906	I	I S 008420	I	I S 016405	I	I S 031115
I	241235	I	I S 001508	I	I S 008421	I	I	I	I S 031117
I	241779	I	I S 001510	I	I S 008451	I	I S 016406	I	I S 031119
I	241892	I	I S 001565	I	I S 008455	I	I	I	I S 031119
I	242627	I	I S 001821	I	I S 008457	I	I S 016407	I	I Z 085058
I	242756	I	I S 001822	I	I S 008499	I	I	I	I
I	242760	I	I S 003054	I	I S 008731	I	I S 016408	I	I
I	242798	I	I S 003055	I	I S 008736	I	I	I	I
I	242800	I	I	I	I S 008818	I	I S 016409	I	I
I	242805	I	I S 003056	I	I S 008999	I	I S 016410	I	I
I	242820	I	I	I	I S 011753	I	I S 017016	I	I
I	242929	I	I S 003057	I	I S 012012	I	I S 018503	I	I
I	242951	I	I S 003058	I	I S 012533	I	I S 018509	I	I
I	242960	I	I	I	I S 012538	I	I S 018511	I	I
I	243178	I	I S 003918	I	I S 012539	I	I S 018515	I	I
I	243183	I	I S 003971	I	I S 012540	I	I S 018517	I	I
I	243190	I	I S 004515	I	I S 012555	I	I S 018527	I	I
I	i	I	I	I	I	I	I	I	I
I	i	I	I	I	I	I	I	I	I